

Zip HydroTap® G4 with CUBE Tap

Boiling | **Chilled** | **Filtered** | **Instantly**

Residential model HT3784UK, with new Zip G4 power-saving technology and Zip 0.2 micron filtration.



New under-sink Zip G4 Command-Centre™ leads the world in energy-saving technology, has a pin-code protected touch-screen to simplify adjustments and automatically monitors performance to give an operating history, if ever required.

HydroTap can be sited at the sink (shown in the inset picture on the left), or on an optional front and drain (shown in the main picture).

Boiling and chilled filtered water, instantly at a fraction of the cost of bottled water.

Features & Benefits - Energy saving

- Superior G4 insulation reduces standby energy consumption.
- Power-Pulse™ technology maintains boiling water within 2°C of set temperature.
- Boiling system is open outlet, vented; factory set to operate at 98°C.
- 'Sleeps' or 'powers-off', after 2 hours of non-use to minimise daily power consumption.
- Automatically 'sleeps' when kitchen goes dark.
- Integral 24/7 automatic timer to complement the user's lifestyle.
- Adjustable boiling temperature set-point.

Using the tap

- The tap may be installed for right or left hand usage.
- Choice of using the rotary control for fast cup filling or hands-free filling of large vessels.
- The select button enables the safe dispensing of boiling and chilled water. Dispense will always default to chilled unless boiling is specifically selected and the safety button will ensure extra safety.

Healthier drinking

- Integral 0.2 micron NSF certified filtration system for healthier drinking water, eliminates the bad taste and odour of chlorine, heavy metals and impurities as tiny as one five-thousandth of a millimetre, but leaves beneficial fluoride.
- Free-Flow™ bottle filling: For continual supply of filtered water, even when chilled capacity is exceeded.

Typical specification

Under-sink instant boiling, chilled filtered water system, equipped with:

Multi-function, electronic tap control.

Integral 5 bar pressure limiting and dual check valve.

NSF certified 0.2 micron filter.

Air-cooled refrigeration system with cleanable lint filter.

Full colour, interactive, touch screen control panel, with pin protection.

Three energy saving modes, including sensor activated 'sleep when dark' function.

BOILING | CHILLED | SPARKLING



Zip HydroTap® G4 with CUBE Tap

Boiling | Chilled | Filtered | Instantly

Model	Tap finish	Code	Boiling	Chilled	Sparkling	Ambient	Mixed hot & cold	Rating (kW @ 230V)	Dimensions W x D x H (mm)
BC	Bright Chrome	HT3784UK	Y	Y	N	N	N	1.55	280 x 470 x 335
BC	Brushed Chrome	HT3784Z1UK	Y	Y	N	N	N	1.55	280 x 470 x 335
BC	Gloss Black	HT3784Z2UK	Y	Y	N	N	N	1.55	280 x 470 x 335
BC	Matt Black	HT3784Z3UK	Y	Y	N	N	N	1.55	280 x 470 x 335

Order code shown here is for the model installed on a sink. To install on a 'font' also specify a font kit, see 'Accessories' below.

Boiling System

Open outlet, vented system, factory set to operate at 98°C.

Flow rate 4.0 l/min.

Chilling System

Fan-cooled condenser type, factory set to operate at 6-10°C.

Flow rate 4.0 l/min.

Refrigerant R134a.

Location

Tap must be positioned so that it drains into a suitable sink, or installed using the optional "tap font kit" which can be plumbed to waste.

Tap should be situated within 1 metre of, and directly above, the under-sink Command Centre™. Maximum distance from the base of the tap to the Command Centre™ is 1 metre. Command Centre™ must have clearances as shown on the drawings.

Ventilation accessories (supplied) must be installed as per instructions.

Approvals

CE endorsed.

Plumbing

Must be installed in accordance with UK Water Supply Regulations.

Designed for direct connection to a potable (drinkable) cold water supply with a minimum pressure of 1.7 bar. A 5 bar pressure limiting valve is fitted internally.

An isolating valve should be installed between the water supply and the Command Centre™.

Electrical

Installation must comply with current IEE regulations.

Connect to 13 amp socket.

Caution

In hard water areas where mineral scale accumulation may be an issue, consideration should be given to the maintenance required.

We recommend use of the Zip Professional high performance limescale filtration system.

Accessories

Zip G4 font kit: Bright Chrome 93441UK
 Brushed Chrome 93441Z1UK
 Gloss Black 93441Z2UK
 Matt Black 93441Z3UK

ZT402 - Zip 0.2 micron replacement filter.
 FL1100G4 KIT - Scale filtration kit.

Technical Support

Contact Zip on:

Tel: 0845 6 005 005 / 0345 6 005 005

e-mail: service@zipindustries.co.uk

Five Year Warranty

Appliance warranty
 36 months, plus additional
 24 months boiling tank warranty.



Sink detail

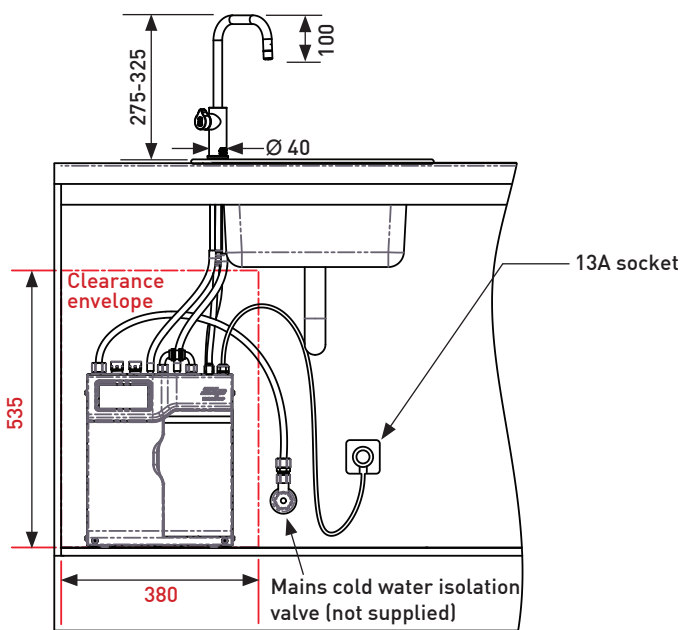

Dimensions in mm

Font detail

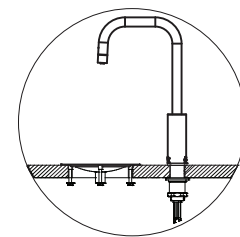

Font Cutouts

