

Showermate Standard Pumps

Showermate pumps are the ideal solution to boost the performance of single shower applications to provide an invigorating showering experience.

Designed for domestic use only, Showermate Standard pumps will function under positive head conditions and are suitable for installation into open vented hot and cold water systems.

Standard pumps require a flow of just 0.8 l/min to start.

Applications

Twin

- Boost hot and cold water supplies equally.
- Single function shower.
- Multi-function shower.
- Bath/basin mixer tap.

Single

- Boost the water pressure to either a hot or cold single tap.
- Boost the blended water between the shower valve and the shower head.

Features include:

- 15 mm push-in flexible hoses with integral isolating valves on inlets.
- Pre-wired with 1.5 metre cable.
- Anti-vibration feet.
- Reassurance of up to a 2-year guarantee (subject to conditions).



**STUART
TURNER**

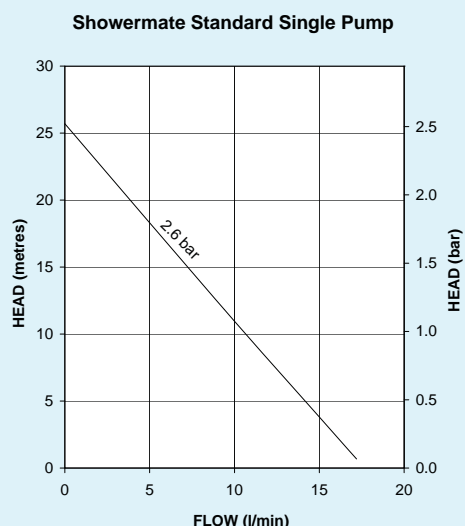
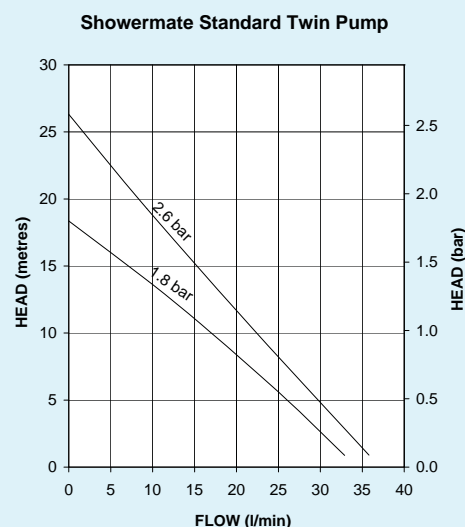

Showermate Standard Pumps



System Booster Pumps	1.8 bar Twin 46407	2.6 bar Twin 46431	2.6 bar Single 46429
Performance (bar) @ 9 l/min	1.5	1.9	1.3
Maximum Flow Litres Per Minute	33	36	17
Maximum Head Valve Closed (bar)	1.8	2.6	2.6
Maximum Inlet Static Head (Metres)	13	13	13
Hoses Flexible 15 mm Push-In	✓	✓	✓
Pump Connection G 3/4"	✓	✓	✓
Carbon Ceramic Mechanical Seal	✓	✓	✓
Flow Switch Sensitivity approx. 0.8 l/min	✓	✓	✓
Negative Airswitch Option Available	✓	✓	✓
WRAS Approved 65°C max	✓	✓	✓
Power Supply 230/1/50	✓	✓	✓
Enclosure Rating BS EN 60529	IP22	IP22	IPX4
Motor Type, Induction, Permanent Capacitor, Auto Resetting Protective Thermotrip	✓	✓	✓
Power Consumption (Watts)	405	505	245
Full Load Amps	1.8	2.2	1.1
Fuse Rating Amps	5	5	5
Pre-Wired	✓	✓	✓
Duty Rating Intermittent (S3) 30 mins on/ 30 mins off @ 9 l/min	✓	✓	✓
Length mm	304	319	223
Width mm	132	132	132
Height mm without flexibles	179	179	179
Gross Weight Packed (kg)	5.3	6.3	4.6

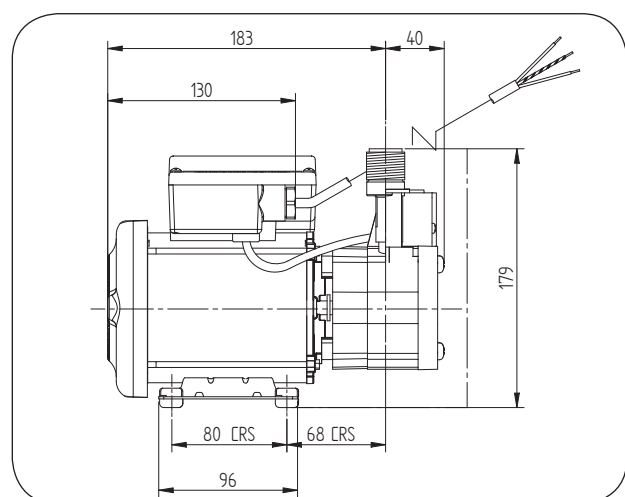
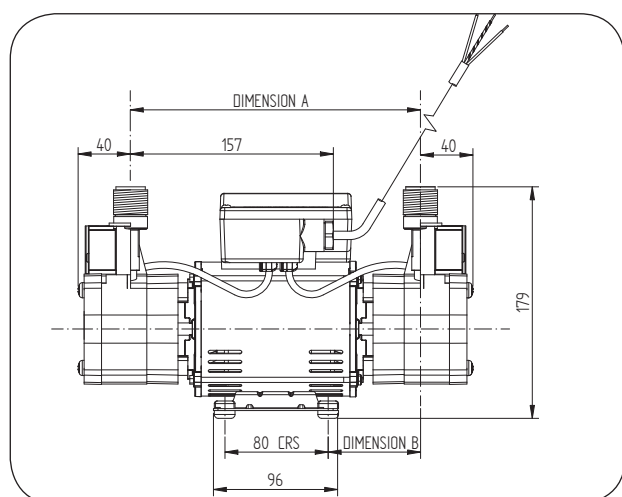

Pump Description	Dim. 'A'	Dim. 'B'
1.8 bar Twin	224 mm	71 mm
2.6 bar Twin	239 mm	79 mm

**STUART
TURNER**

Stuart Turner Ltd
Henley-on-Thames
Oxfordshire RG9 2AD
England
Telephone: +44 (0)1491 572655
Fax: +44 (0)1491 573704

Email:
pumps@stuart-turner.co.uk
Web:
www.stuart-turner.co.uk

V.A.T. REG. No. 199 0987 92.
Registered in England No. 88368.
Registered Office:
Market Place, Henley-on-Thames