

# Monsoon Standard Single Pumps

Where an open vented positive head system exists with a minimum gravity flow of 0.6 l/min, then the Monsoon Standard is the perfect solution.

## Application

Standard single pumps are ideal for boosting water pressure and flow.

They can be used to:

- Boost the water pressure in either the hot or cold water supply.
- Boost the blended water outlet between the shower valve and the shower rose.

Not suitable for pumping water supplies to common mixers.

## Features

- Robust brass bodied construction
- 2.0 - 4.5 bar performance options
- Continuously rated
- Hard faced carbon/silicon carbide seal
- Supplied with 22 mm push-in x 300 mm anti-vibration flexible hoses with integral isolating valves.
- G 3/4 threaded connections.
- Pre-wired with 1.5 metre cable
- Anti-vibration feet.
- 5-year guarantee (subject to conditions)



Monsoon Standard Single Pumps

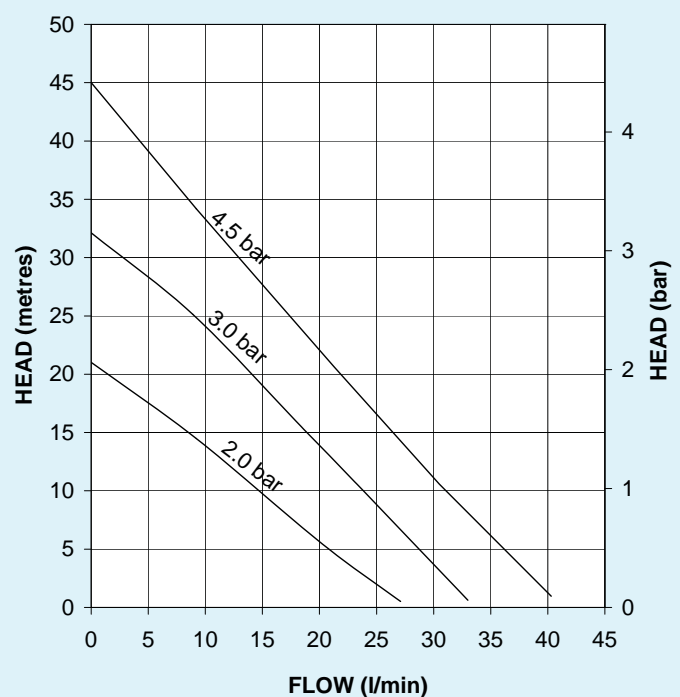

# Monsoon Standard Single Pumps



System Booster Pumps		2.0 bar Single 46497	3.0 bar Single 46419	4.5 bar Single 46420
Performance (bar) @ 9 l/min (one shower)		1.5	2.5	3.5
Performance (bar) @ 18 l/min (two showers)		0.7	1.6	2.4
Maximum Flow Litres Per Minute		27	33	40
Maximum Head Valve Closed (bar)		2.0	3.0	4.5
Maximum Inlet Static Head (Metres)		8	14	14
Hoses	G ¾" Female x 22 mm Push-in c/w isolating valves x 305 mm long	✓	✓	✓
G ¾" Male Pump Connections		✓	✓	✓
Inlet Strainer		✓	✓	✓
Stuart Hard Faced Mechanical Seal		✓	✓	✓
WRAS Approved 65°C max		✓	✓	✓
Flow Switch Sensitivity approx. 0.6 l/min		✓	✓	✓
Pressure Switch				
PCB	Run On Timer 3 Sec			
	Dry Run Protection	✓	✓	✓
Power Supply 230/1/50		✓	✓	✓
Enclosure Rating BS EN 60529		IPX4	IPX4	IPX4
Motor Type, Induction, Permanent Capacitor, Auto Resetting Protective Thermotrip		✓	✓	✓
Power Consumption (Watts)		245	385	555
Full Load Amps		1.1	1.7	2.4
Fuse Rating Amps		5	5	5
Pre-Wired		✓	✓	✓
Duty Rating Continuous (S1) @ 9 l/min and above		✓	✓	✓
Length mm		200	200	200
Width mm		126	126	126
Height mm without flexibles		202	202	202
Gross Weight Packed (kg)		6.5	6.5	7.1

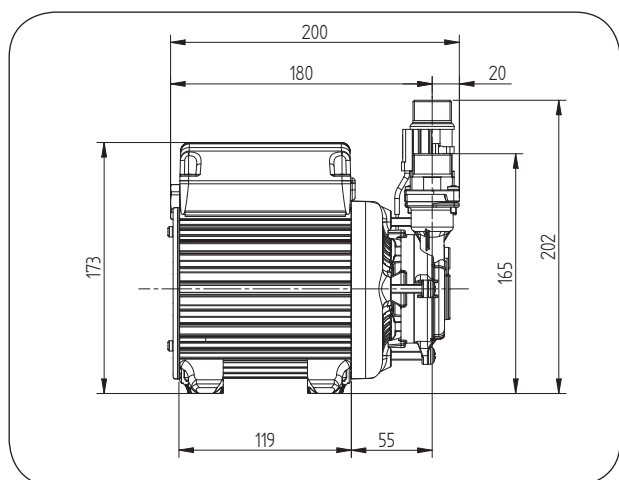

## STUART TURNER

Stuart Turner Ltd  
Henley-on-Thames  
Oxfordshire RG9 2AD  
England  
Telephone: +44 (0)1491 572655  
Fax: +44 (0)1491 573704

Email:  
pumps@stuart-turner.co.uk  
Web:  
www.stuart-turner.co.uk

V.A.T. REG. No. 199 0987 92.  
Registered in England No. 88368.  
Registered Office:  
Market Place, Henley-on-Thames