

# Monsoon Universal Single Pumps

Monsoon Universal pumps remove the guesswork from pump selection. Fully automatic, they will function under both positive and negative head conditions and are suitable for installation into an open vented hot and cold water system. Universal Monsoon pumps do not require a gravity flow of water to start.

## Application

Universal single pumps can be used in pairs to boost hot and cold water supplies independently, or as a single pump to boost a water supply as required.

They can be used to:

- Boosting a hot water service to a common mixer where the cold supply is mains fed.
- Boosting hot and cold supplies separately.
- Increasing water pressure to a combi boiler via a break tank.

## Features

- Robust brass bodied construction
- 2.0 - 4.5 bar performance options
- Continuously rated
- Hard faced carbon/silicon carbide seal
- Supplied with 22 mm push-in x 300 mm anti-vibration flexible hoses with integral isolating valves.
- G 3/4 threaded connections.
- Pre-wired with 1.5 metre cable
- Anti-vibration feet.
- 5-year guarantee (subject to conditions)



Monsoon Universal Single Pumps

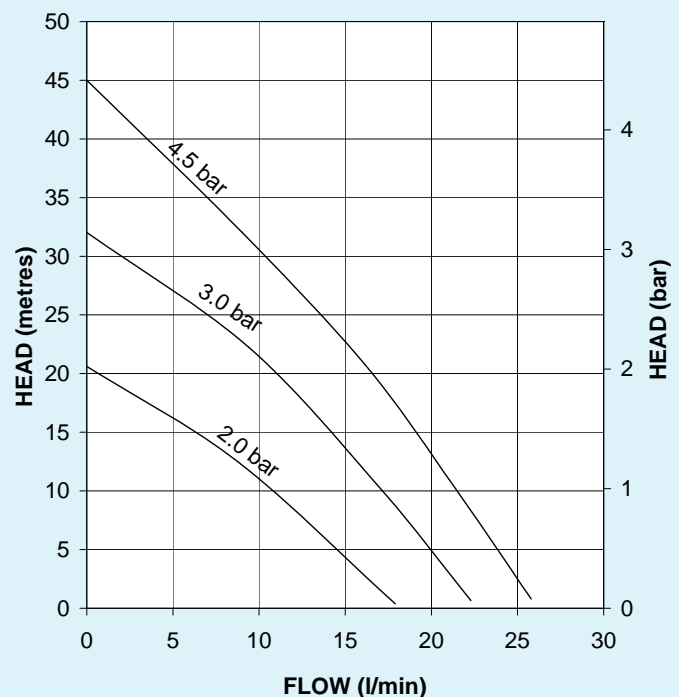

# Monsoon Universal Single Pumps



System Booster Pumps		2.0 bar Single 46498	3.0 bar Single 46413	4.5 bar Single 46414
Performance (bar) @ 9 l/min (one shower)		1.2	2.5	3.5
Performance (bar) @ 18 l/min (two showers)		N/A	0.9	1.7
Maximum Flow Litres Per Minute		18	22	26
Maximum Head Valve Closed (bar)		2.0	3.2	4.5
Maximum Inlet Static Head (Metres)		8	12	12
Hoses	G 3/4" Female x 22 mm Push-in c/w isolating valves x 305 mm long	✓	✓	✓
G 3/4" Male Pump Connections		✓	✓	✓
Inlet Strainer		✓	✓	✓
Stuart Hard Faced Mechanical Seal		✓	✓	✓
WRAS Approved 65°C max		✓	✓	✓
Flow Switch Sensitivity approx. 0.6 l/min		✓	✓	✓
Pressure Switch		✓	✓	✓
PCB	Run On Timer 3 Sec	✓	✓	✓
	Dry Run Protection	✓	✓	✓
Power Supply 230/1/50		✓	✓	✓
Enclosure Rating BS EN 60529		IPX4	IPX4	IPX4
Motor Type, Induction, Permanent Capacitor, Auto Resetting Protective Thermotrip		✓	✓	✓
Power Consumption (Watts)		250	390	555
Full Load Amps		1.1	1.7	2.5
Fuse Rating Amps		5	5	5
Pre-Wired		✓	✓	✓
Duty Rating Continuous (S1) @ 9 l/min and above		✓	✓	✓
Length mm		200	200	200
Width mm		162	162	162
Height mm without flexibles		243	243	243
Gross Weight Packed (kg)		7.8	7.8	8.4

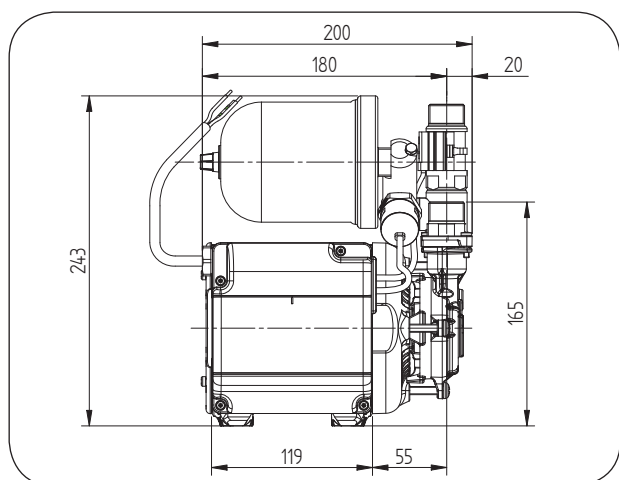

**STUART  
TURNER**

Stuart Turner Ltd  
Henley-on-Thames  
Oxfordshire RG9 2AD  
England  
Telephone: +44 (0)1491 572655  
Fax: +44 (0)1491 573704

Email:  
pumps@stuart-turner.co.uk  
Web:  
www.stuart-turner.co.uk

V.A.T. REG. No. 199 0987 92.  
Registered in England No. 88368.  
Registered Office:  
Market Place, Henley-on-Thames