

SANIFLO

Professional Range



**Heavier Duty
Pumps & Macerators
for Commercial Applications**

www.saniflo.co.uk

The Professional Range at a glance

The Professional Range takes Saniflo technology to a higher level and provides more opportunities for Pump Specialists.

This brochure provides in-depth technical detail relating to the Professional Range of products.

The Saniflo Professional Range extends the benefits of Saniflo technology from the domestic to the commercial sector which may now take advantage from the brand's quality, longevity and service support – in situations where the addition of facilities is hampered by remote soil stacks or drainage.

The Professional Range comprises seven products that are tough enough to perform in some of the most demanding situations where it is necessary to deliver waste water over a distance of 100m or vertically to a height of 11m using small bore discharge pipework.



Sanicubic is one of the most powerful pumps in the Saniflo Professional Range. It has been designed for discharging waste from multiple WCs and other waste water producing appliances.

Page 4



Sanibest accepts waste and water from a WC, hand basin, shower and urinal. The unit features a new, high performance 1100 Watt motor, combined with a radical macerator action powerful enough to cope with the occasional sanitary item accidentally disposed of in the WC.

Page 13



Sanicom is the second pump in the Professional Range. It has a powerful oil and fan cooled motor encased in aluminium housing and is intended for busy environments such as restaurants (care homes etc).

Page 8



Sanicom2, with its 2 x 1500 Watt motors, gives the added security where continuity of service is important.

Page 9



Sanispeed is a pump which is intended for light commercial situations.

Page 10



Sanicondens Best is an essential pump for the disposal of condensate from gas boilers, air conditioning units or dehumidifiers. It incorporates a neutralising tray for the treatment of acidic condensate from condensing boilers.

Page 3

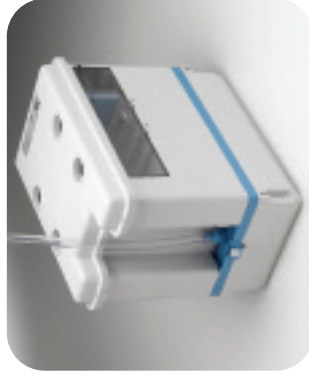

Sanicondens Plus is an essential pump for the disposal of condensate

Page 3



- Saniflo units are fully guaranteed for two years and backed by a nationwide service network.
- For Technical Advice and Spares call 020 8842 4040

- Visit the website www.saniflo.co.uk for a full listing of Service Engineers.
- Service Engineer Linkline: 08457 650011

Please phone from a landline from the unit location in order to be automatically connected to your local Service Engineer

SANIFLO

The Professional Range comprises seven products specially designed for heavier duty applications.

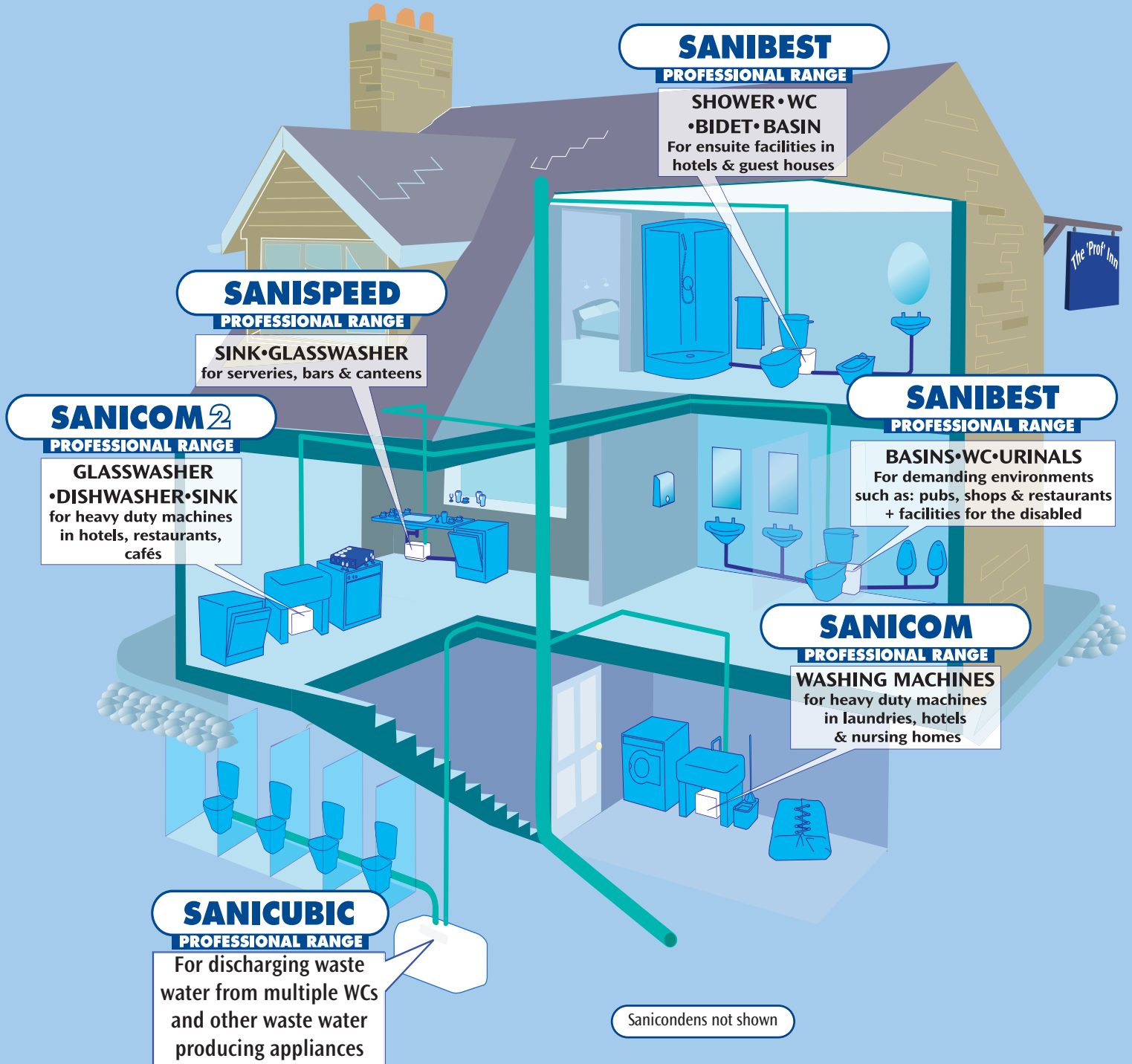

Hotels, restaurants, cafés, guesthouses, pubs, clubs, and bars, factories, offices, shops, laundries and nursing homes. Just a few of the demanding environments in which the Professional Range will solve plumbing problems.

SANICONDENS PLUS (Ref No 1082/3) & SANICONDENS BEST* (Ref No 1082/2)

*Specifically designed for disposing of acidic condensate.



- pumping height up to 4.5m
- maximum flow rate 342 litres / hour
- flow rate at 4 metres 156 litres / hour
- PH mini 2.5
- electrical power supply 220-240 V / 50 Hz
- motor power rating 60 W
- maximum power consumption 0.38 A
- protection index IP20
- acoustic level < 45 dBA
- admissible waste water temperature 35°C
- maximum admissible waste water temperature 80°C
- weight 1,9 kg
- measurements l x d x h
Sanicondens Plus: 277 x 160 x 146 mm
Sanicondens Best: 279 x 160 x 254 mm
- volume 2.1 litres
- accessories supplied: non-return valve, wall fixing kit, 2 inlet adaptors, connection for an alarm, 2 metres electric cable, 6 metres drainage pipe

DESCRIPTION

Quiet and light, it is designed to operate with water at a mean temperature of 35°C and occasionally with water up to 80°C and a minimum pH of 2.5.

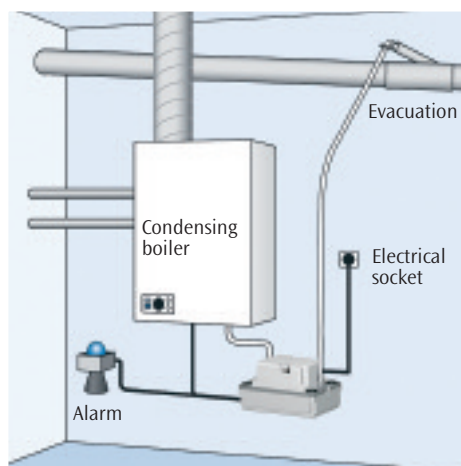
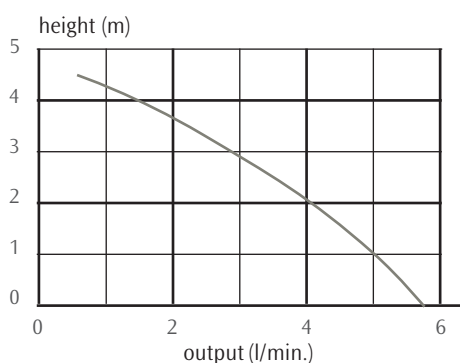

SANICONDENS PLUS

Condensate pump

As per Sanicondens Best for situations where a neutralising tray is not required



High performance macerating pump discharging waste and water from multiple WCs and other appliances.



- Pumps up to 11m vertically through 50mm pipework
- Pumps to 100m horizontally or a lesser combination of vertical and horizontal
- Inlet diameter 110mm for WC waste, 40mm for waste water
- Handles waste water of up to 70°C
- Dual motors for absolute reliability and power
- Two alarms – one unit mounted, one remote
- Power supply: 230-240V AC 50Hz Domestic Supply

SANICUBIC OPERATING PRINCIPLE

SANICUBIC® contains 2 separate pumps. Each of the pumps is fitted with a high-performance maceration system. The 2 pumps operate alternately. In the event of inflow overload, both motors run at the same time (or if one of the pumps is faulty, the other one takes over).

The SANICUBIC® tank is fitted with 2 dip tubes; one tube controls motor operation, and the other one controls the alarm system.

- Long pickup tube (normal operation): as soon as the waste water level in the tank reaches the triggering point in the long tube, the pumping system starts up.

- Short pickup tube (inflow overload operation): if the waste water level in the tank reaches the upper point, a contact is closed and the auxiliary pumping system is triggered. The contact also sets off an audible and visual alarm.

The general alarm LED on the SANICUBIC® control panel switches to red. The system sends a high-frequency overload signal to the remote alarm unit. The SANICUBIC® is fitted with a remote alarm module that transmits a visible and audible alarm (HF link).

Note: Isolating valves must be fitted with a Sanicubic installation. If isolating valves are not fitted this may make service/maintenance impossible and invalidate your warranty. These valves are available through your merchant.

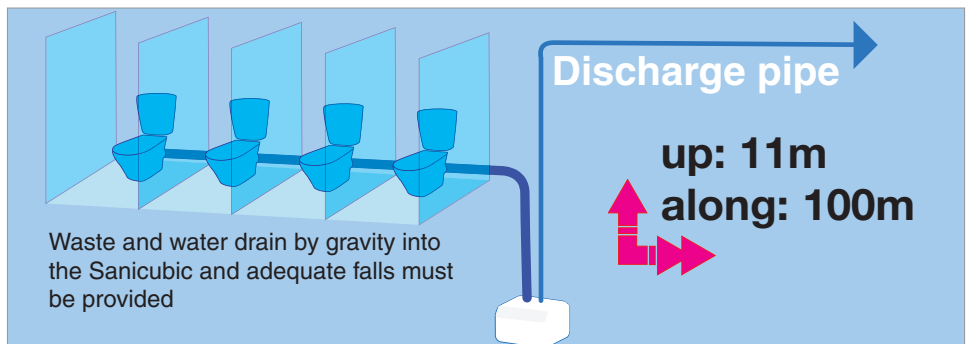

DIMENSIONS AND OVERALL MEASUREMENTS

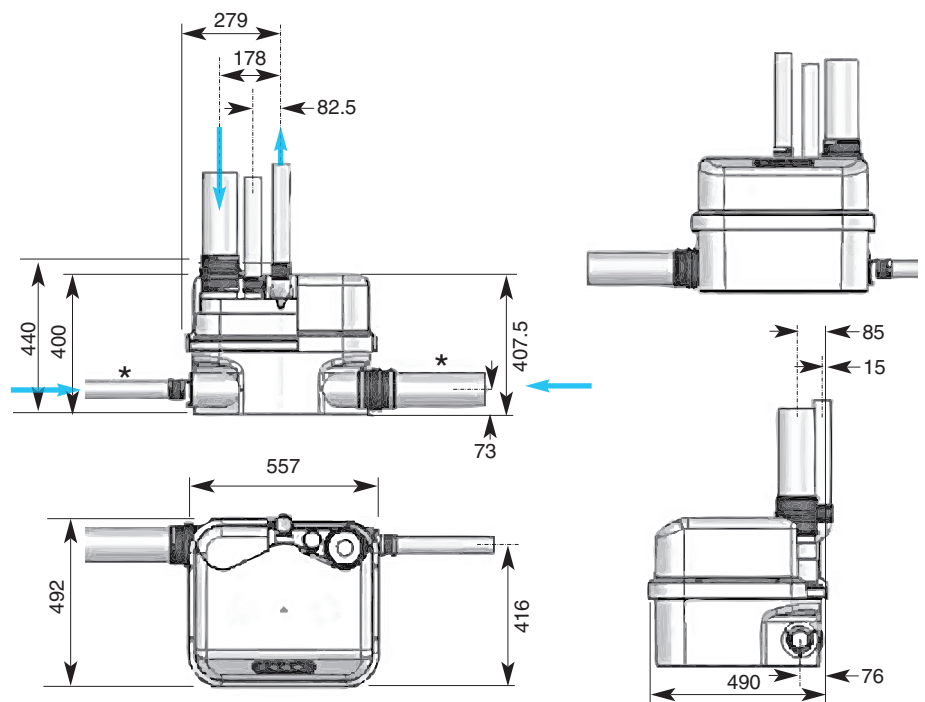

TECHNICAL DATA

TypeR300
Maximum discharge head11m
Voltage220-240V
Frequency50Hz
Volume47 l
Maximum power input2x 1500w
Maximum current input13A
Electrical classificationI
Average water temp for optimum performance35°C
Maximum temperature (intermittent)70°C*
Protection indexIP67
Net weight (including accessories)	...30kg
European Standard: EN 12050 – 1 – install 12056	

*Hot water drain cycles from dishwashers or washing machines

Waste from multiple WCs and other waste water producing appliances. (The combined inputs must not exceed 80% of those shown in the graph below).

PERFORMANCE CURVE

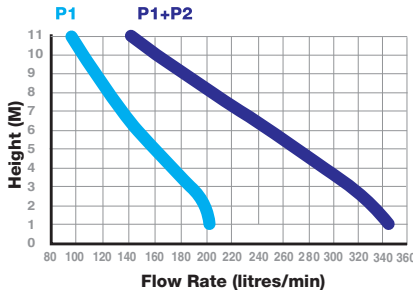

Example: Pump P1 is operating normally. It discharges 160 l/min at a pumping height of 5 m. If pump P1 shows any signs of weakness or if the waste water inflow is too great, pump P2 starts up. The output is then increased to about 275 l/min, until the situation returns to normal.

IMPORTANT INSTALLATION SPECIFICATIONS FOR SANICUBIC

1. Attention: the space in which the SANICUBIC® is to be installed must be large enough to leave at least 600 mm of working room around and above the unit to facilitate such maintenance work as may be required. There must be sufficient lighting and it must be sufficiently well ventilated and protected from freezing.

2. Isolation valves must be fitted on the 50mm discharge pipe work and on all inlet pipe work including WCs and other sources. This is required by the standard EN 12056 and to allow any possible maintenance work to be carried out without serious flooding.

Note: If isolation valves are not fitted service/maintenance may be impossible and any associated costs will not be covered by the Saniflo warranty. 4"/110mm and 2"/50mm isolation valves can be purchased from your merchant when placing your order for Sanicubic.

3. The discharge pipe must be fitted so as to

RATIO OF HEIGHT / LENGTH FOR DISCHARGE

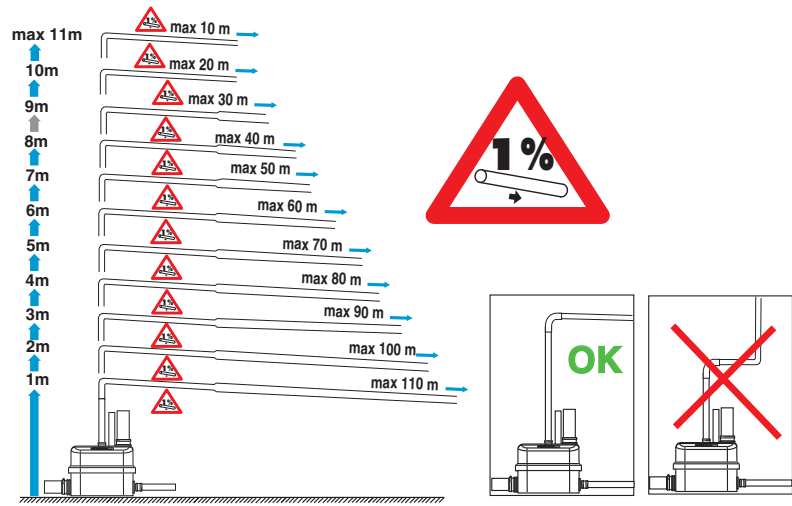

SANICUBIC® complies with standard EN 12050-1 (lift station for household waste containing faeces) and with the European directives covering construction products, electrical safety and electromagnetic compatibility. This unit must be installed and used in compliance with European installation standard EN12056 and with local requirements.

avoid all back flow from the drainage system. Back flow can be avoided by installing an anti-back flow riser reaching a high point above the maximum back flow level. Comment: In the absence of local information to the contrary, the maximum back flow level corresponds to street level (roadway, pavements, etc.). Continue the discharge pipework after the anti-backflow

riser using a larger diameter pipe. 4. If the Sanicubic is installed in a space such as a pit for example, we would recommend the fitting of a bilge pump in case of flooding. 5. The Sanicubic must be vented with an outlet at roof level. The vent should be taken from one of the two 40mm connections located either side of the

INSTALLING THE ANTI BACKFLOW LOOP

The discharge pipe must be fitted so as to avoid all back flow from the drainage system. Back flow can be avoided by installing an anti-back flow riser reaching a high point above the maximum back flow level.

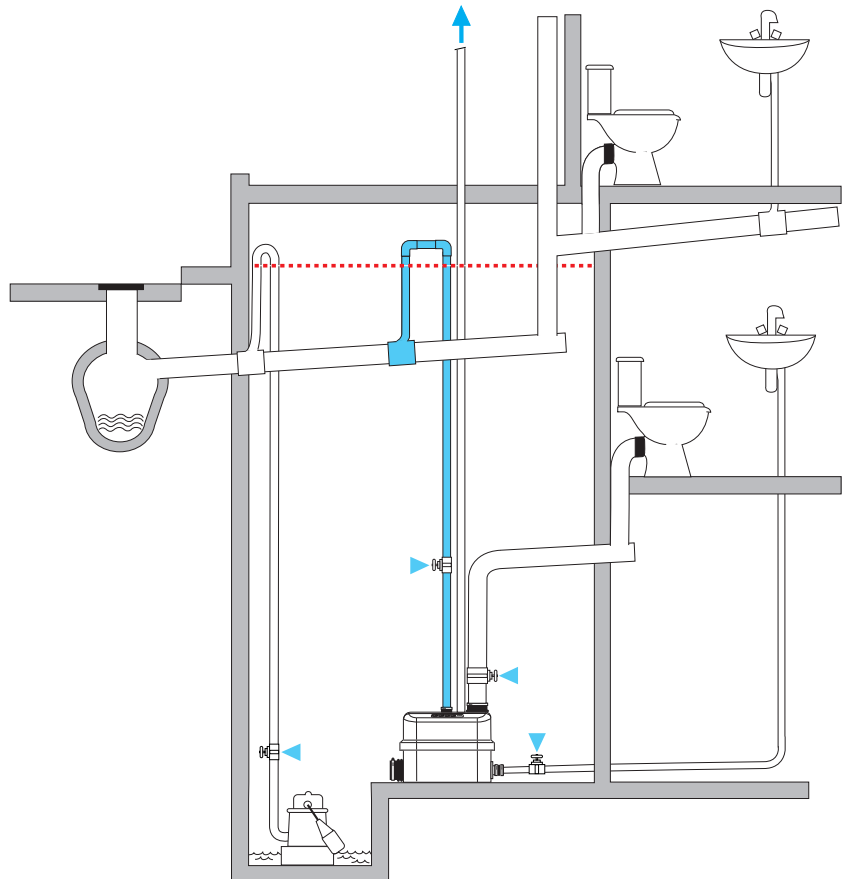

50mm discharge outlet. The Sanicubic will not be able to operate at all if this vent connection is not opened up!

Do NOT fit air admittance valve on the top of the air vent pipe. The vent must be an open vent or the unit will not operate.

6. The lifting station must be fixed to the floor (see paragraph in Section 8-8).

Alarm Operation

SANICUBIC®

Société Française d'Assainissement

EN 12050-1

R300

220-240 V - 50 Hz

3000 W



General Alarms

High level alarm :

If the water level in the unit is abnormally high: the buzzer is triggered and the red LED comes on; the other motor starts up 3 seconds later (see the illustration showing the control keyboard).

Temporary alarm :

If one of the 2 motors runs for more than 1 minute : the buzzer is triggered and the red alarm LED comes on; the other motor starts up 3 seconds later.

Mains power supply alarm:

In the event of a mains power failure (or if the unit is unplugged) : the buzzer is triggered and the red alarm LED comes on; the yellow mains power LED also flashes.

Resetting General Alarms

If the problem that has triggered one of the alarms referred to above ceases, the buzzer stops, but the red alarm LED stays on to memorize the fact that there has been an operational problem.

The "Reset alarm" key on the keyboard is used to switch the buzzer off in all cases, but it only switches the red LED off if the problem that triggered the alarm has been dealt with. The alarm lights on the remote control box also stay on until the problem has been dealt with. This avoids the risk of the unit being left operational without attention being given to a potential cause for failure.

The electronic system measures the current input (I a) to each motor and enables detection of 2 types of fault:

- I a < I minimum threshold, which can be due to: a fault in the motor power supply (short-circuit), a capacitor fault, disconnected internal pipes (eg. through blockage) (turbine / macerator system).

- I a > I maximum threshold, because the macerator system is blocked.

Both of these cases lead to the following results: the motor in fault status stops, the corresponding red LED comes on, the alarm is triggered and the second motor is started. If the power consumption of the second motor is also outside the limits: that motor also stops and the corresponding red LED comes on.

The buzzer can be stopped by pressing the "Reset alarm" key, but the red motor LED stays on. When the "override" key for the corresponding motor is pressed the green LED comes on if the fault is no longer present. Until the "override" key for the motor is pressed the unit continues to operate on one motor. The "override" key is used to re-initialise the program. The unit then attempts to operate using both motors (alternately).

GENERAL ALARMS

UNIT ALARM

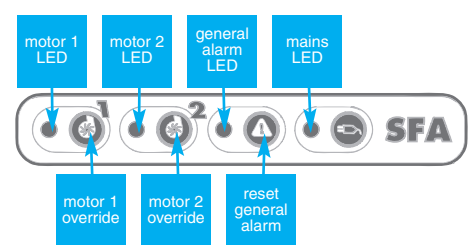

REMOTE ALARM

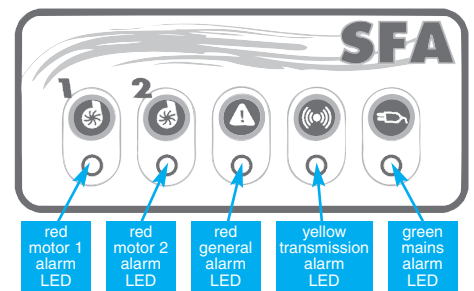

The remote alarm module is connected to the SANICUBIC® via an HF link. It receives the various types of alarm information from the unit.

USE

- 1 The SANICUBIC® unit is designed to drain off household waste water. Any other use will invalidate the guarantee. Do not dispose of sanitary towels, condoms, hygiene articles, oils, solvents, acids, or any other potentially corrosive or explosive liquids etc, via the unit.
- 2 **Warning!** In the event of a power failure, stop draining any water from the equipment connected to the SANICUBIC unit.
- 3 Do not install or use the unit in a zone where there is a risk of explosion.

MAINTENANCE

A visual check of the lift station must be made once a month to make sure it is operating correctly, and the installation must be inspected regularly (once a year) by a qualified person. Meanwhile, if any technical problems are experienced, please call our after sales service.

CONNECTING THE INLETS DN 40/50 SANICUBIC

Lower inlets (dia.1)

Upper inlets (dia.2)

- Cut off the end of the DN 50 inlet with a saw.
- Cut the sleeve (D) to suit the pipe diameter: DN 40 or DN 50 (dia.3).
- Fix the sleeve on the inlet and on the pipe, using the collars.

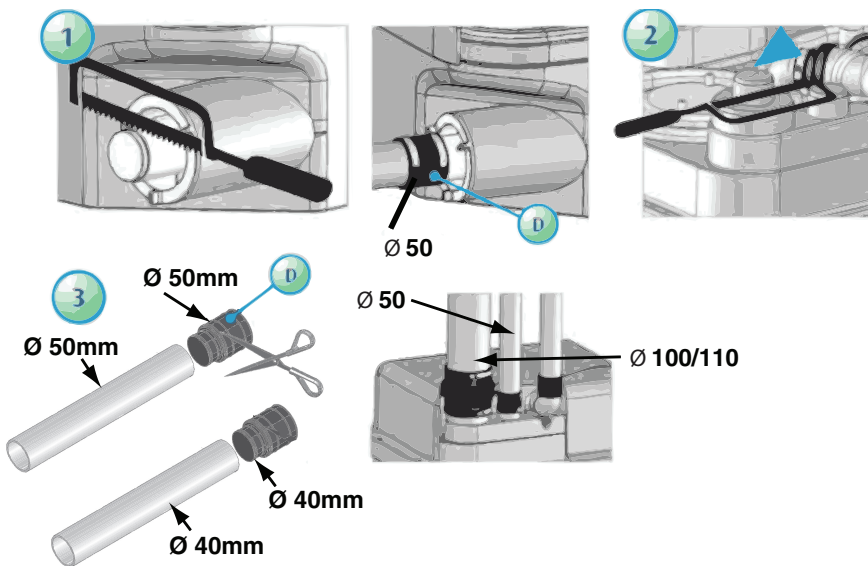

CONNECTING THE DN 100/110 INLET

Lower inlets (dia 1)

- Remove the plug from the side inlet.
- Fix the sleeve (F) in place using the collar (J).
- Fully insert the DN 100/110 tube in the other end of the sleeve and fix it in place using the other collar (J).

Upper inlets (dia 2)

- Cut off the upper end of the DN 100 inlet with a saw.
- Fix the sleeve (F) in place using the collar (J).
- Fully insert the DN 100/110 tube in the other end of the sleeve and fix it in place using the other collar (J).

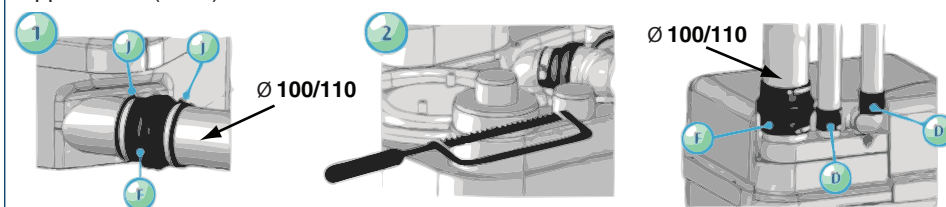

SOLVING TROUBLE AT MILL



High performance macerating pump discharging waste and water from multiple WCs and other appliances

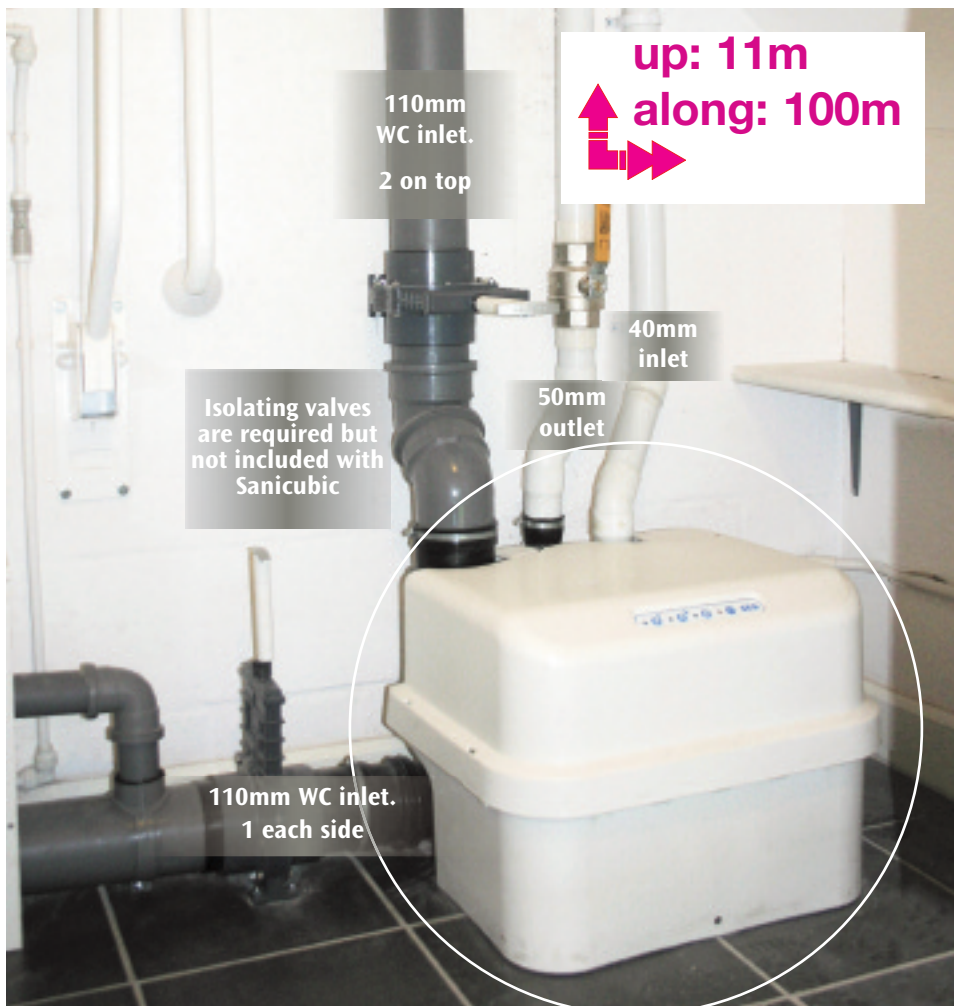

A Sanicubic unit has been installed in the basement of the cottage to pump waste and water to the mains, which is situated some distance away.

Site manager Peter Bowler said—*'The system seems to be working well pumping from the undercroft up to a man hole at road level, this should save us £217 every ten days when the cottage is let, so thank you for your help!'*

The Arkwright Society preserves the historically important mills in Cromford site of the first successful water powered cotton spinning mill. The Arkwright society is a charity and to raise funds one of the cottages has been converted into a holiday let and exhibition. Prior to conversion the cottage which is sited on conservation land had a septic tank which was both expensive to empty and gave problems of leakage. As water purity is closely monitored the cottage needed to be connected to mains drainage and this could only be done with a Saniflo pumping system.

Heavy duty pumps for discharge of waste water for heavy commercial use



- Working temperature 35°C. Maximum temperature 90°C for short periods.
- 2 side entries (ø 40mm)
- Air vent / or connection to exterior
- Discharge pipework: ø 32mm/ ø 40mm
- Maximum Horizontal discharge (1:100) 100m Maximum Vertical Discharge Height 10m (or a lesser combination of both)
- Dimensions – H=330mm W=490mm D=230mm

Sanicom is a lifting pump for waste water used in commercial applications (restaurants, hairdressing salons, the catering industry etc.). The unit operates automatically, has a high performance level, and is safe and reliable, provided all the rules for installation and maintenance in this notice are strictly followed.

INSTALLATION

FITTING

The Sanicom can be fixed to the floor, preventing it from turning or moving.

1. Warning: The space in which the Sanicom is installed must be large enough to leave at least 600mm around the unit for easy maintenance. This space must be well lit, ventilated, and must never be immersed in water and must be protected from frost.
2. Isolation valves should be fitted to the inlet pipework and discharge pipework to isolate the unit in case of the need for service.

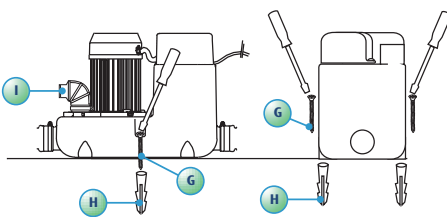

HOW IT WORKS

The Sanicom contains 1 pump. The tank is equipped with a sensor tube which controls the automatic activation of the motor when waste enters the unit. As soon as the waste enters the tank, the pump starts.

PERFORMANCE CURVE

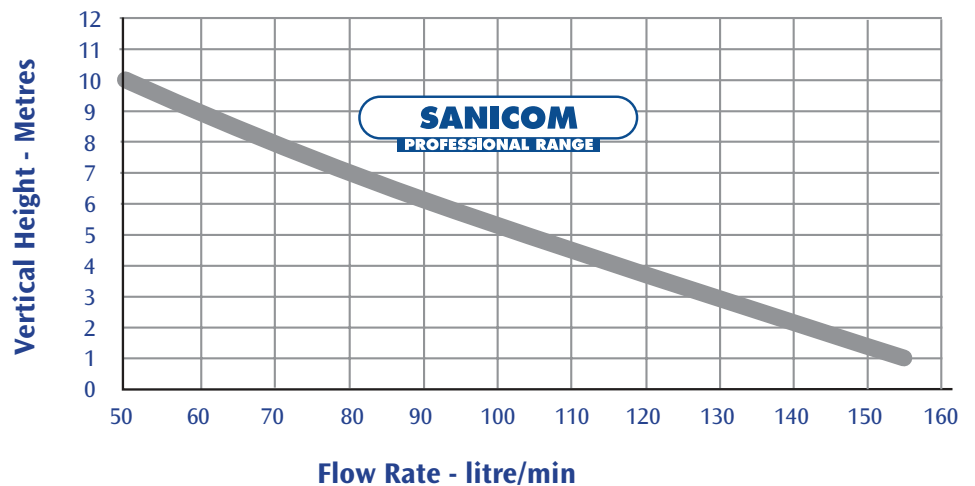

HEIGHT AND LENGTH OF THE DISCHARGE PIPE

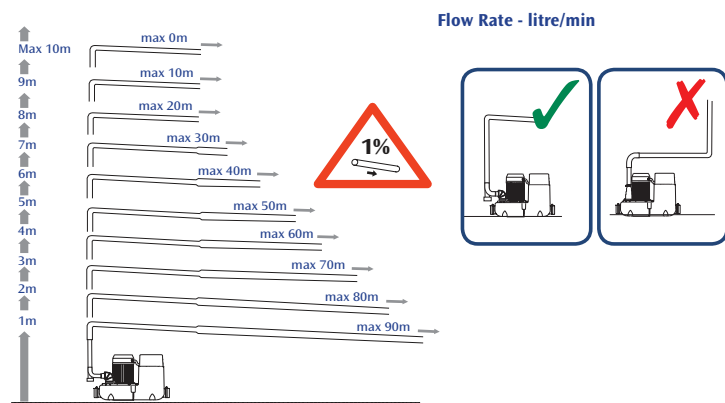

CONNECTION TO SOIL AND VENT PIPE OR DRAIN

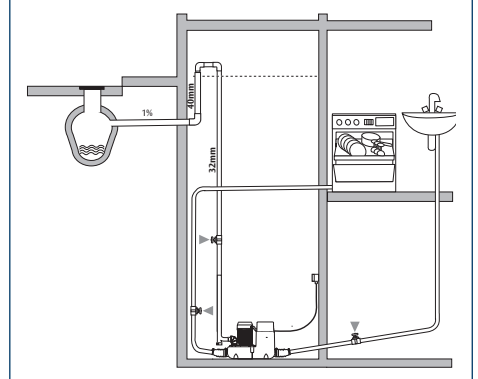

Application	Commercial sink, washing machine, dishwasher or shower* or bath*
Type	FF03-P95
Maximum vertical pumping height	10m
Voltage	220 – 240 V
Frequency	50 Hz
Maximum power consumption	1300 W
Maximum current consumption	3.3 A
Electrical class	I
Protection index	IP44
Max temp with intermittent functioning	90°
Net weight	10 kg

* In the case of bath or shower tray, make sure the waste traps are raised 15cm above floor level.

CAUTION: 1. All applications other than those described in this notice are prohibited.
2. Do not exceed an incoming flow rate greater than 80% of the flow rate stated on the design curve in any of the apparatus.

CONNECTION TO SANITARY WARE

To connect a bathtub (or shower), make sure the waste trap height is raised by at least 15cm above floor level. Connection must be made using 40mm or 50mm diameter pipework, with minimum slope of 1%.

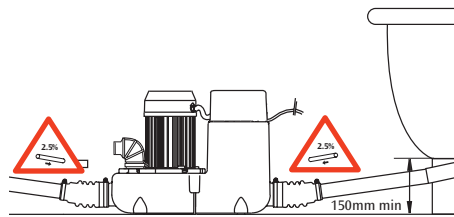

The disposal of waste from the Sanicom can be discharged through a 32mm diameter copper or plastic pipes (or PVC, ABS, etc.). This discharge pipe must be designed so as to prevent back-flow from the sewers. See diagram above. Horizontal discharge pipework should maintain a 1% fall (1cm/M) to the soil and vent pipe. If a vertical rise is required, this must be installed at the start of the run, before the horizontal section. The horizontal section should then have a minimum 1% fall to the final drain point.

Take care that the discharge valve flap faces the direction of flow. If the end of the discharge pipework is much lower than the unit, install a riser pipe about 80mm long from the highest point of the discharge run and fit an air admittance pipe on top (capable of withstanding at least 15psi pressure.) to break the syphon. The discharge should be connected to a 100mm discharge stack via a strap boss connector.

CONNECTION TO SIDE INLETS

Use the flexible inlet connector (A) for side inlet connections. Using a metalwork saw, saw off the desired inlet point, remove any burrs and then fix the flexible inlet connector with the hose clip (D). We recommend the installation of a grease trap for applications with a high grease inflow.

Connection to the inlet can be made using a 40mm or 50mm pipe. To make a 50mm connection, cut off the end of sleeve (A) beforehand.

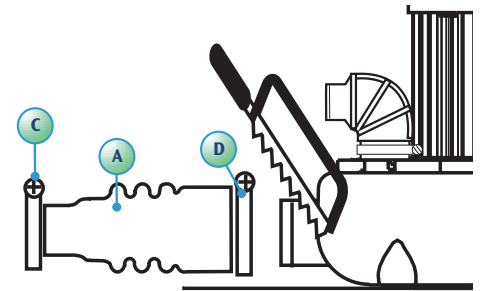

SANICOM2 (Ref No1046/2)

Two motors for even greater security



Sanicom2 is a lifting pump with 2 x 1500 Watt motors for security of continuity of service

- 3 side entries (ø 40mm)
- Discharge pipework: ø 32mm/ ø 50mm
- Maximum Horizontal discharge: 100m (1:100 fall)
Maximum Vertical Discharge Height: 11m (or a lesser combination of both)
- second motor for failsafe back-up

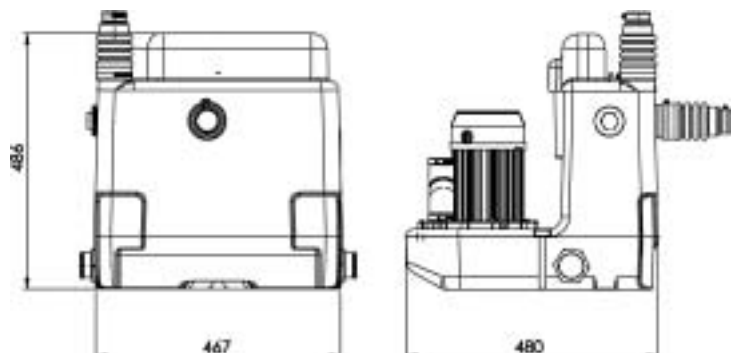

CONNECTION TO SANITARY WARE

To connect a bathtub (or shower), make sure the waste trap height is raised by at least 25cm above floor level.

SANISPEED (Ref No 1045)

Commercial pump



- Working temperature 35°C maximum temperature, 75°C for short periods.
- Maximum Horizontal discharge (1:100) 70m
Maximum Vertical Discharge Height: 7m (or a lesser combination of both)
- 2 side entries (ø 40mm)
- 2 cover entries (ø 40mm)
- Discharge pipework: ø 32mm / ø 40mm
- Air vent
- Motor power rating 400 Watts
- Shaft: stainless steel
- Impeller: single disk ø 81mm
- European Standard EN 12050-2

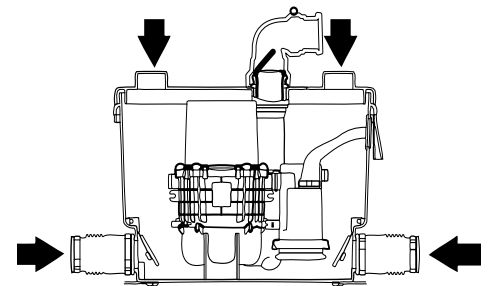

DESCRIPTION

This unit is a pump that will clear the waste from a shower and washbasin, bath, washing machine, glass washer and a sink in a light commercial situation.

PERFORMANCE CURVE

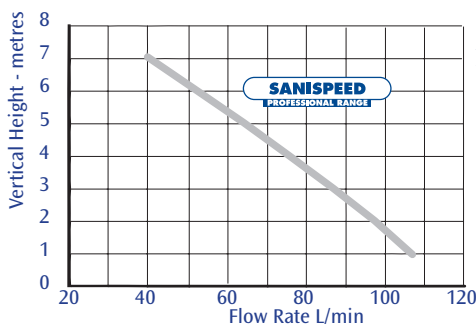

The discharge pipe size for Sanispeed must be 32mm.

DIMENSIONS AND OVERALL MEASUREMENTS

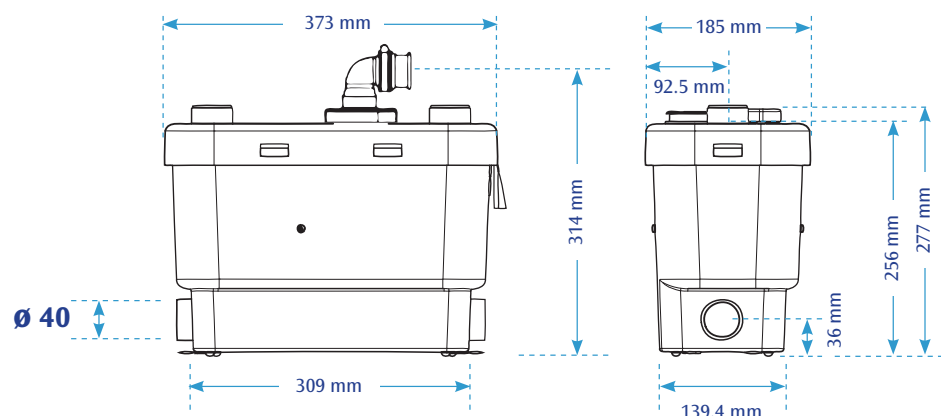

INSTALLATION

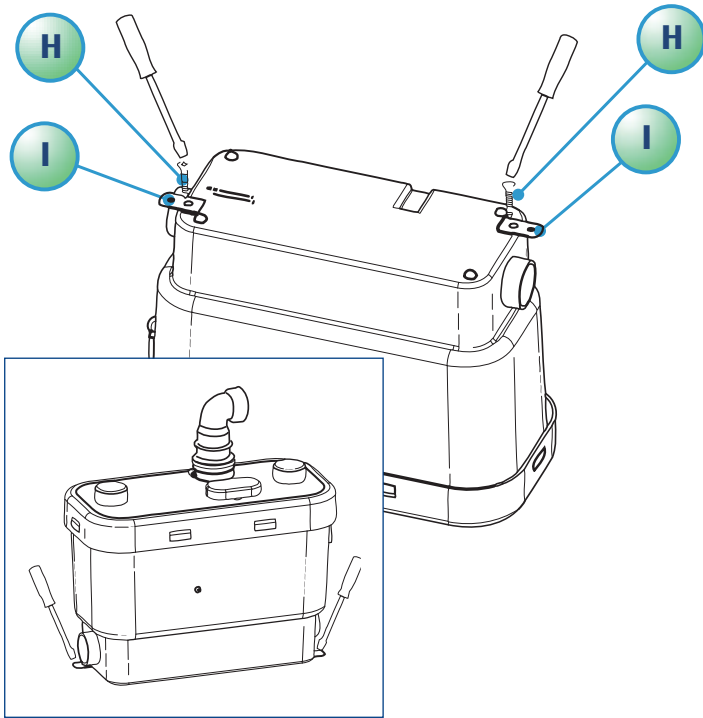

The unit should be accessible for possible maintenance. It is supplied with floor fixing lugs to prevent it from moving during use. If pumping vertically, always put the vertical before the horizontal at the start of the pipework.

CONNECTION TO SIDE INLETS

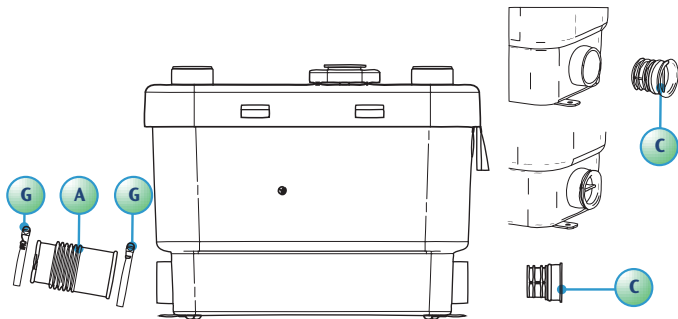

Use the rubber connector (A) for connection of pipes to the side inlets. Secure with the metal hose clips (G). Cap off unused inlets with the end caps (C) provided, after greasing the joints.

CONNECTION OF BATHROOM APPLIANCES

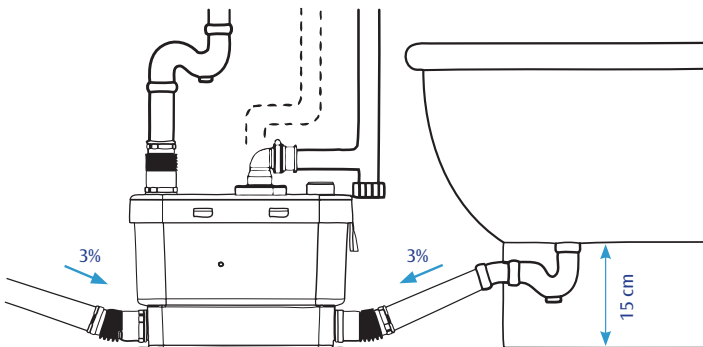

To connect a shower/bath, ensure that the trap exit is 15cm above floor level. Although not obligatory, a lid connection may be used to run an external air vent.

HEIGHT AND LENGTH OF THE DISCHARGE PIPE

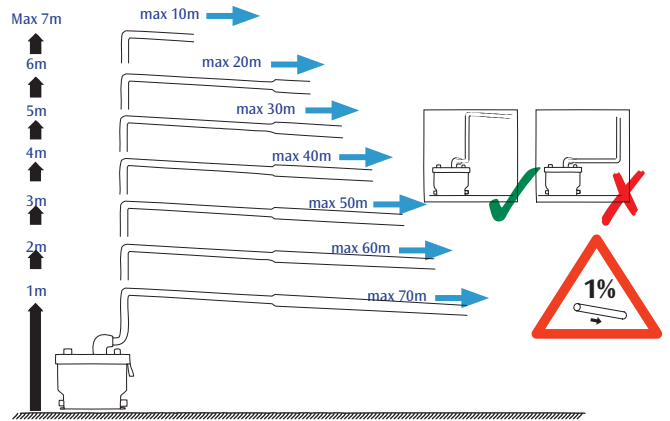

CONNECTION TO LID INLETS

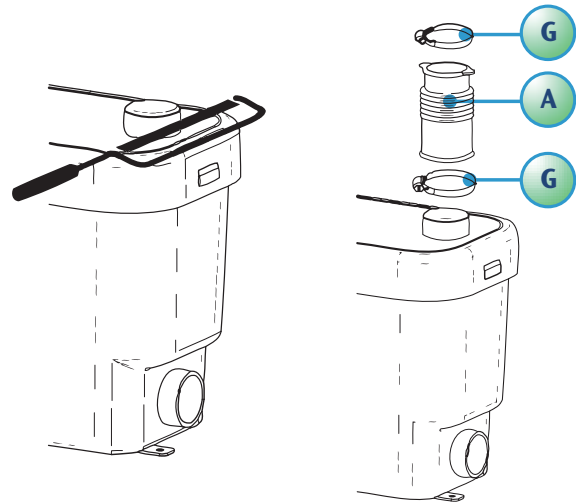

To connect to a lid inlet, cut off the sealed cap with a hacksaw and connect using the rubber connector (A) provided. Tighten with the metal hose clips (G).

DISCHARGE CONNECTION

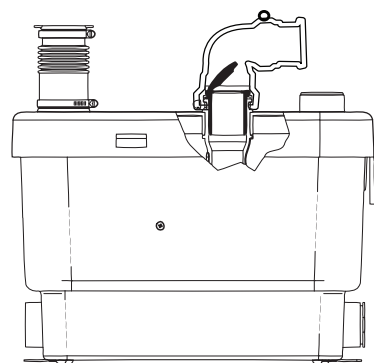

Note: The discharge pipework should be 32mm copper or rigid solvent weld plastic. Observe the pumping parameters of the unit (vertical and horizontal combination, step 4). All horizontal pipe runs must have a minimum fall of 1:100 (10mm per metre) all the way to the drain.

Technical advice for discharge to lower floor

If the discharge pipework runs to a level considerably lower than the unit, the resultant siphoning effect can suck out the water seal in the unit. Fitting an air admittance valve capable of withstanding 10psi pressure at the high point of the pipe run will overcome this problem.

Orient the opening end of the non-return valve in the direction of the discharge. Secure with the metal hose clip (F).

IN CASE OF SERVICING

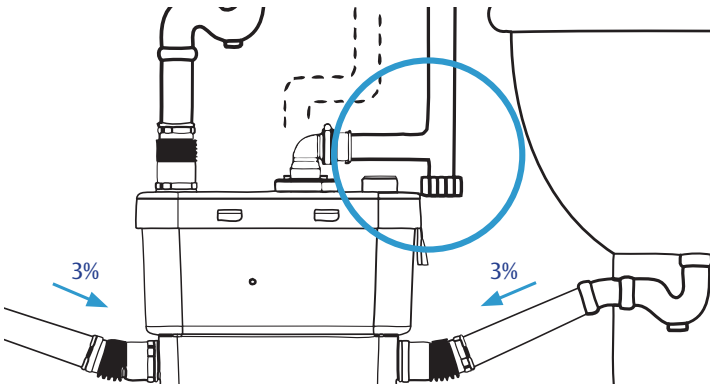

For possible service requirements, provide a drain off at the low point of the installation.

Care and use

The Sanispeed is designed to handle the waste evacuation from a bath, kitchen sink, dishwasher and washing machine - in a light commercial situation. Its powerful pump will deal with every day normal usage.

Warning: Do not dispose of solvents, paints (do not wash paint brushes in sink), caustic, acid or other chemicals into these products.

Depending on usage, the unit may need to be cleaned from time to time. Heavy usage can result in a build up of fat and grease.

The unit will pump away water as hot as 75°C for a short time (i.e. to clear the hottest waste water from a washing machine). However, do not pour boiling water directly into the unit.

When pumping very hot water for a prolonged period of time, the unit will automatically cut out to protect the motor (thermal cut-out). When this happens the unit will shut down long enough to cool down (approx. 1 hour) and automatically resume normal operation when ready.

Norms

The unit conforms with EN 12050-2 waste water lifting plant.

SANISPEED®

Société Française d'Assainissement

EN 12050-2

FF02-V45

220 - 240 V - 50 Hz - 400 W - IP44 2A - 6,4 KG



Sanispeed knows the drill

***“This facility
could not exist without
the use of Saniflo
products”***

Anthony Corris

When Corris Construction were called in to install a new University training facility they immediately encountered drainage problems. No external pipework could be used and there was limited space in the under floor area so draining waste by gravity to the soil pipe was a major problem. The answer was to use Sanispeed a powerful drainage pump to discharge waste water to the main soil pipe.

Sanispeed has proved extremely efficient where there were previously no alternatives to gravity drainage and is very popular in areas of heavy use.

Seven Sanispeed pumps were installed to take waste water away. Sanispeed is designed for light commercial situations. Designed to work with water at 35C it can operate at 75C for short periods. Pumping up to 70m horizontally, its maximum discharge height is 7m with a flow rate at this height of 43 litres/minute



SANISPEED: A commercial pump for discharge of waste water from kitchen and utility rooms

Heavy duty macerator pump for high usage environments



- Maximum Horizontal discharge (1:100)100m Maximum Vertical Discharge Height: 7m (or a lesser combination of both)
- Working temperature 35°C.
- 2 side entries (ø 40mm)
- 1 cover entry (ø 40mm)
- Air vent
- Discharge pipework: ø 22/32mm
- New design for ease of access
- Starting mechanism: microswitch
- European Standard EN 12050-3

DIMENSIONS AND OVERALL MEASUREMENTS

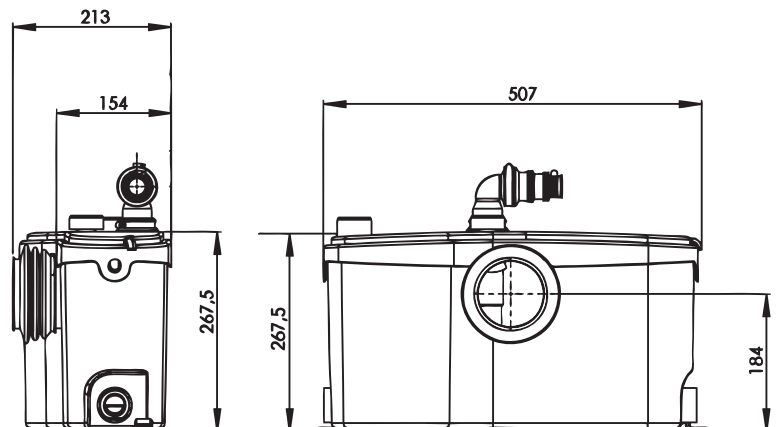

DESCRIPTION

Sanibest is a high performance pump/macerator for normal WC waste, toilet paper and waste water in accordance with the relevant regulations.

Sanibest is suitable for heavy usage situations and will handle water for short periods at 90°C. This pump/macerator has been designed to pump away the waste from a WC and the sanitary appliances shown above. Sanibest is a robust machine which is capable of handling the occasional sanitary article accidentally flushed down the WC. Installed and used correctly, Sanibest will give consistent and reliable service.

PERFORMANCE CURVE

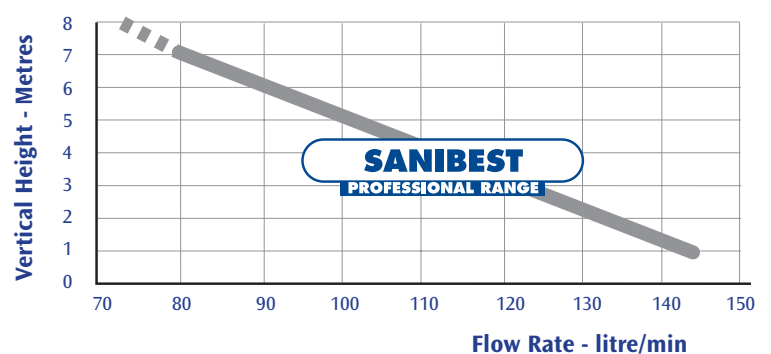

HEIGHT AND LENGTH OF THE DISCHARGE PIPE

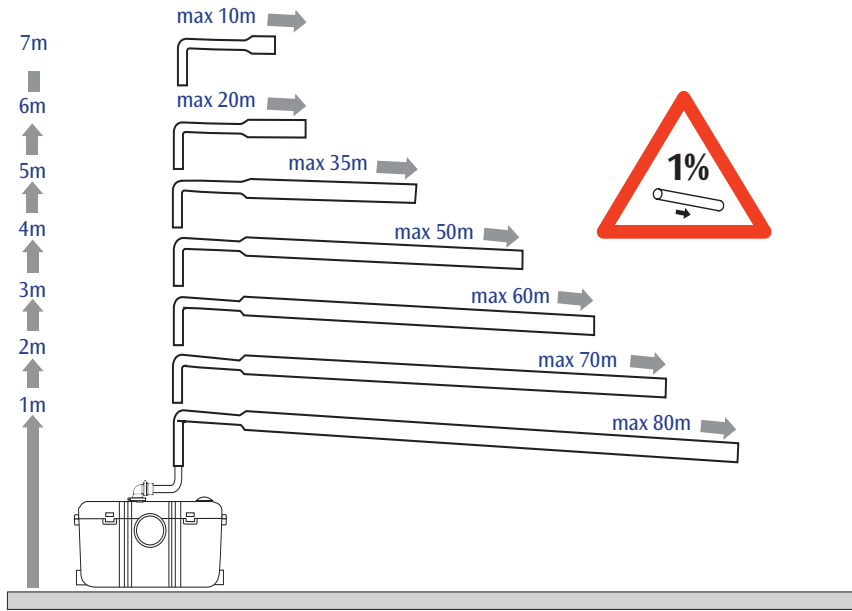

CONNECTION TO A WC

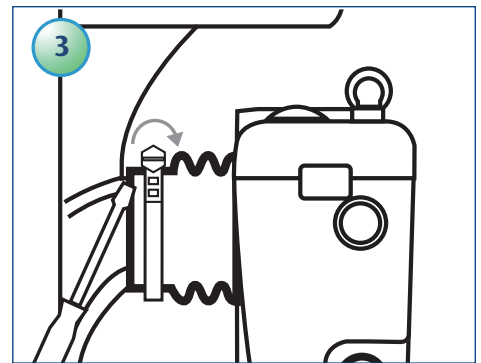
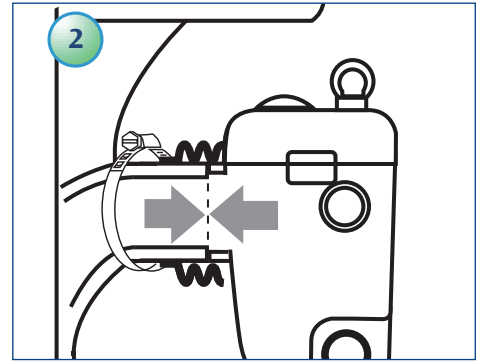
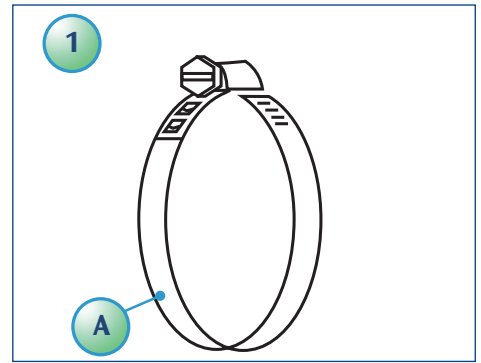

Pull flexible sleeve over the pan spigot (fig 1)
Position the jubilee clip over the edge of the flexible sleeve (fig 2), and tighten with a screwdriver (fig 3).

INSTALLATION

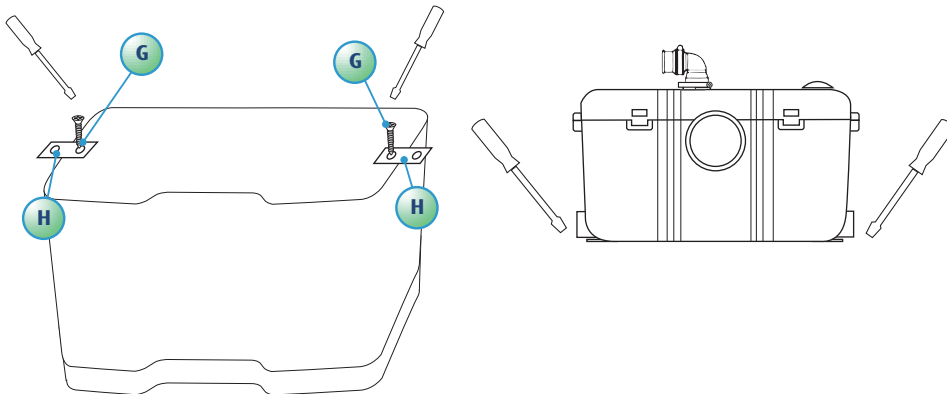

WARNING: The unit must be connected to a WC pan with a horizontal outlet spigot conforming to EN33 or EN37 norms.
The unit should be installed so that it is accessible for possible maintenance.
The unit can be fixed to the floor to prevent it from moving or turning.

CONNECTION OF THE OTHER SANITARY APPLIANCES

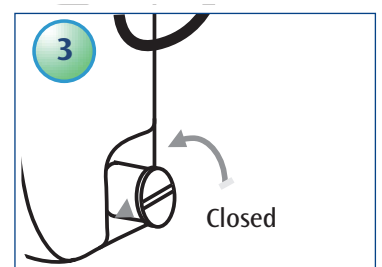
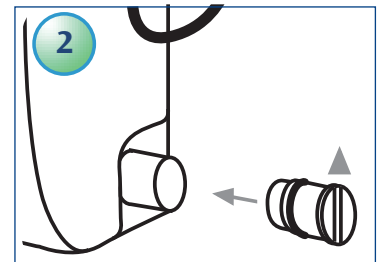
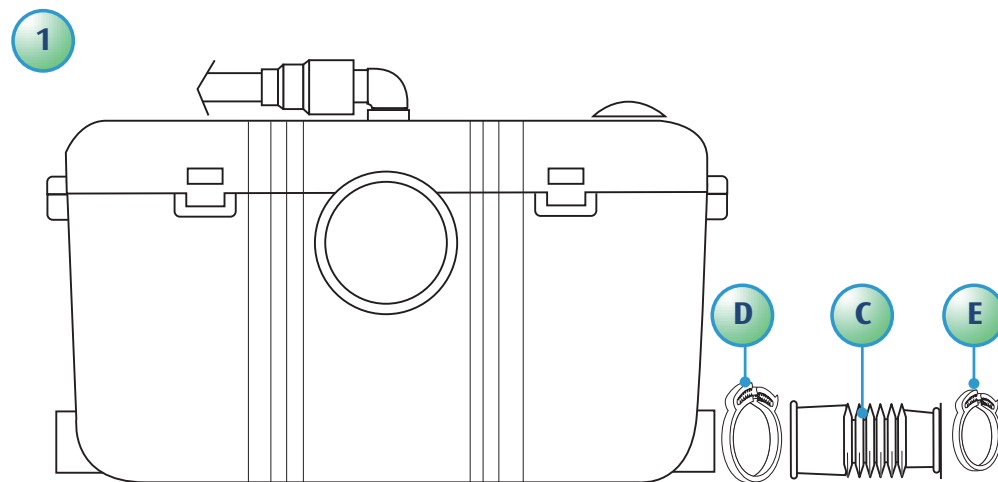

To connect to the side entries of the case, use the rubber connector (C). Secure with plastic clips (D) and (E).

Plug the unused inlet with blanking plug (F) after greasing the joint.

Warning: Ensure when connecting a shower to the Sanibest that the underside of the shower tray is raised by at least 15cm from the floor.

CONNECTION OF THE DISCHARGE PIPEWORK

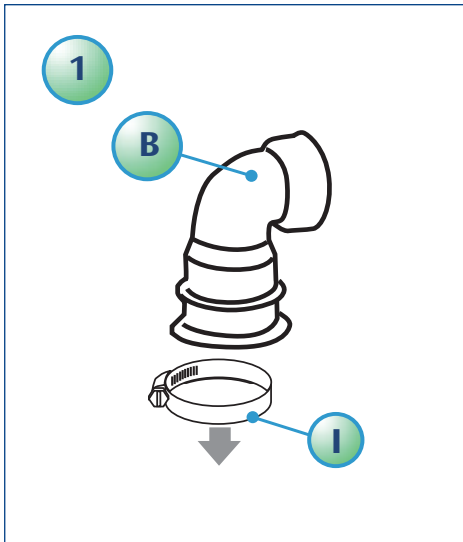

- 1 Attach the rubber discharge elbow (B) to the outlet pipe and secure with steel hose clip (I).
- 2 Connect the other end to 22mm (3/4") copper or rigid UPVC pipe.
- 3 Horizontal pipe runs must have a minimum fall of 1:100 (10mm per metre) to the soil stack.
- 4 If a vertical lift is required, it must be made before the horizontal run at the start of the pipework.
- 5 We would recommend that a drain-off point is installed to allow the discharge pipework to be drained down before any service work.
- 6 If the discharge pipework runs to a level considerably lower than the unit, the resultant siphoning effect can suck out the water seal in the unit. Fitting an air admittance valve capable of

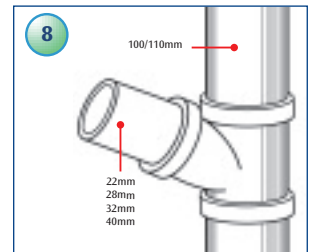
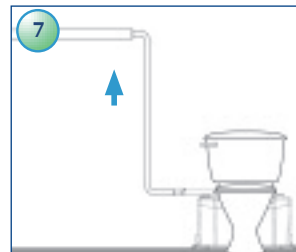
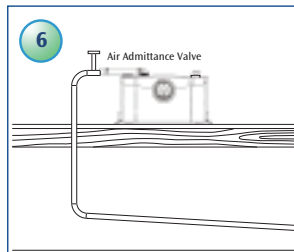
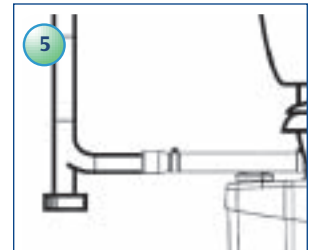
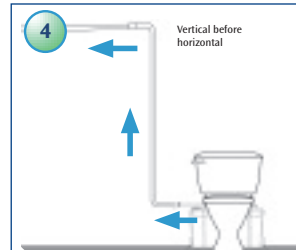
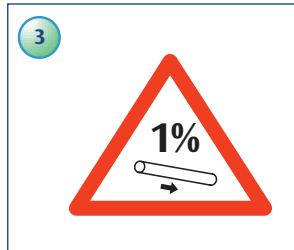
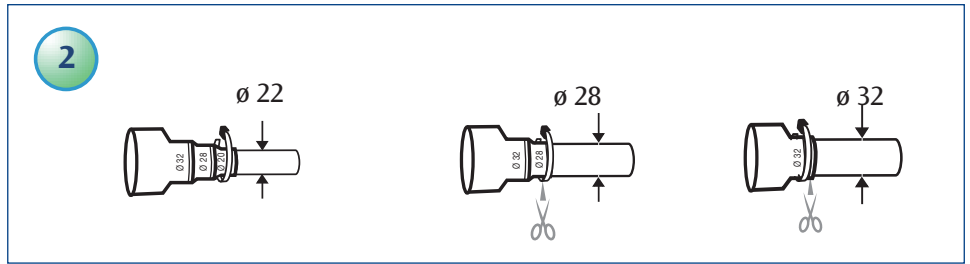

- 7 Ensure all external pipework is adequately lagged to avoid the possibility of freezing.
 - 8 The discharge pipework must be connected to the soil stack using an appropriate strap on boss.
- N.B. Any elbow on the discharge pipe of

withstanding 10psi pressure at the high point of the pipe run will overcome this problem.

the unit will create friction loss (roughly 50cm per elbow to be deducted from the vertical pumping specification). Always use smooth bends (or 2 x 45 degree bends together) and not 90 degree elbows. Note. The discharge pipework should be copper or rigid solvent weld plastic (22mm or 32mm).

VENTING

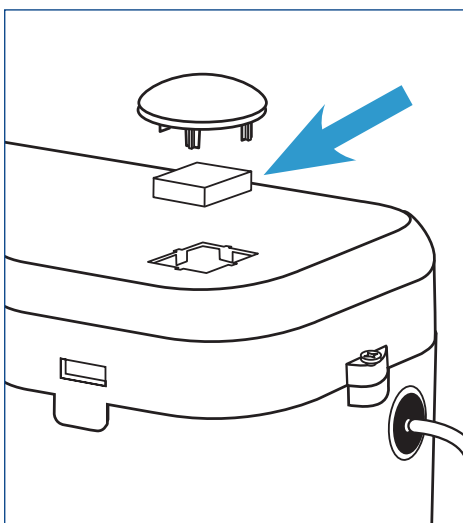

Sanibest is fitted with an active carbon filter, and requires no external venting.

EXAMPLE OF SANIBEST INSTALLATION

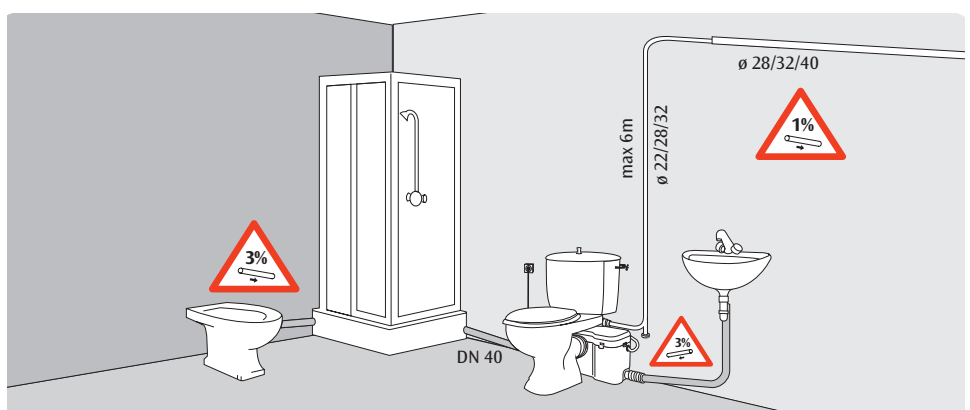

NORMS

Sanibest conforms to EN 12050-3.
Lifting plant for wastewater containing faecal matter for limited applications.
SANIBEST®

Société Française d'Assainissement
EN 12050-3/02
LA05-B81
220 - 240 V - 50 Hz - 750 W - IP44



SANIBEST TECHNICAL DATA

Application	1 WC + shower + bidet + washbasin
Maximum Vertical Pumping	6m
Maximum current consumption	3,5 A
Normal Power Rating	760 W
Electric Class	I
Type	LA05-B81
Degree of protection	IP44
Net Weight	9,5 kg
Voltage	220-240 V
Frequency	50 Hz

Usage

A WC fitted with a Sanibest pump/macerator does not require any special maintenance. The Sanibest will operate automatically as soon as the required level of water enters the case.

Warning: The water authorities strongly discourage the disposal of sanitary items such as condoms, tampons and sanitary pads via a WC.

However, should such items be flushed down a WC attached to Sanibest, the unit is able to accept these items without blocking.

Damage will occur to the Sanibest if hard objects (eg metal, wood etc) are flushed via the WC, or aggressive chemicals such as acids, caustics, solvents etc.

Best in class!



Located in Basingstoke and consisting of an Infant and Junior School, Hatch Warren School continues to strive for outstanding results, the accolade awarded them by Ofsted in previous years.

As part of an improvement programme new classrooms were constructed. During the works a steel pin driven through the floor shattered a mains drain pipe! The repaired pipe still seeped waste unfortunately which was of course unacceptable. The cost of lifting the floors and replacing the pipe would have been enormous and it was decided that the simplest and most economic solution was to install four new improved Sanibest macerator pumping units provided by Saniflo.

Sanibest enables any waste to be pumped up into ceiling voids and across corridors via a 22mm pipe so that facilities can be installed for any area. In this case 30-35 metres of 22mm pipework had to be run through the existing wide bore drain and connected to four Sanibest units serving four toilet cubicles. With its new exceptionally efficient macerator cutting action Sanibest is capable of dealing with the occasional sanitary item accidentally disposed of in the WC and is thus the preferred unit for locations such as offices and hotels and is ideal for Schools.



THE INFORMATION BELOW IS CORRECT FOR ALL PRODUCTS IN THE PROFESSIONAL RANGE

ELECTRICAL CONNECTION



- The electrical installation should be carried out by a qualified person and conform to BS 7671 1992 requirements for electrical installation.
- These products require a 220/240V single phase 50 Hz supply (UK specification) and should be connected to an unswitched fused wiring connector protected by a 5 amp fuse (Sanicubic 13 amp fuse), or a 30 mA circuit breaker set at 5 amp, (13 amp for Sanicubic).
- The unit should be sited at least 60cm away from any shower tray.

GUARANTEE

Saniflo units are fully guaranteed for two years and backed by a nationwide service network.

THE DOMESTIC RANGE

SANIFLO

DOMESTIC SMALL-BORE SANITARY SYSTEMS

Add extra facilities from loft to basement and most places in between

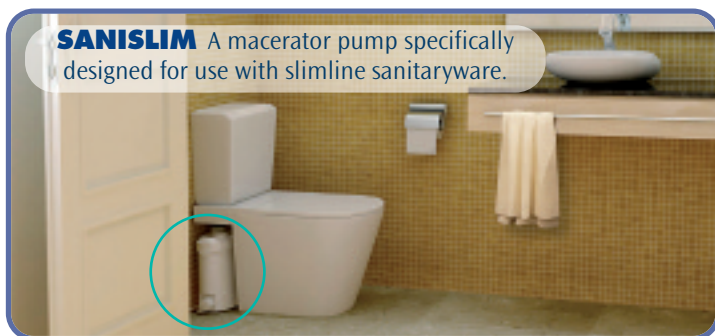
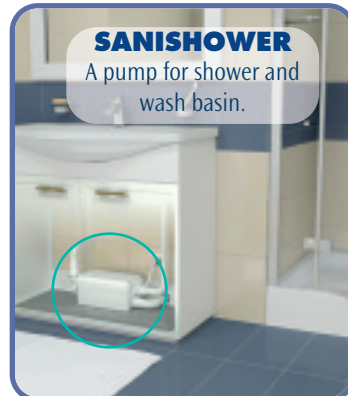
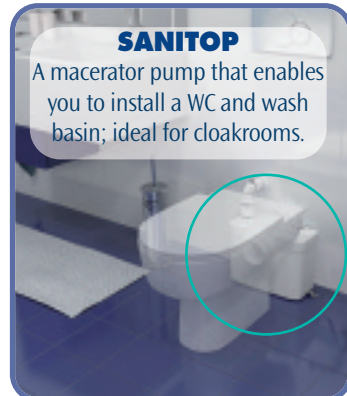

check out the website for details: www.saniflo.co.uk

Check out www.saniflo.co.uk for ...



SANIFLO

Saniflo Ltd. Howard House, The Runway, South Ruislip, Middx. HA4 6SE
Tel: 020 8842 0033 Fax: 020 8842 1671 e-mail: sales@saniflo.co.uk

Copyright 2011 Saniflo Ltd. All rights reserved. No part of this publication may be reproduced, stored in a retrieval system or transmitted in any form or by any means, electronic, mechanical, photocopying, recording, computerised or otherwise without prior arrangement with and permission of Saniflo Ltd.

NB: Our pumping systems are designed for the disposal of normal organic waste product, water or paper. They are not intended to replace kitchen waste or sanitary waste disposal units. As our policy is one of continuous product improvement we reserve the right to alter product specification and price without notice. All information in this publication is given in good faith. No responsibility can be accepted for any errors, omissions or incorrect assumptions. Illustrations are diagrammatic and should be regarded only as indicative of technical requirements. All vertical pumping distances are measured from base of unit.