

HANDY NO-TOUCH ELECTRIC HANDWASH

Fitting Instructions and User Guide

INTRODUCTION

Thank you for purchasing a Heatrae Sadia Handy. The Handy instantaneous water heater is manufactured to the highest standards and has been designed to meet all the latest relevant safety specifications.

This Handy instantaneous water heater must be installed (Sections 4.0-7.0), commissioned (Section 8.0) and maintained (Sections 9.0 - 10.0) by a competent person. Please read and understand these instructions prior to installing your Handy instantaneous water heater. Particular attention should be paid to the section headed SAFETY (section 2.0). Following installation and commissioning the operation of the heater should be explained to the user (Section 8.0) and these instructions left with them for future reference.

This appliance is not intended for use by persons (including children) with reduced physical, sensory or mental capabilities, or lack of experience and knowledge, unless they have been given supervision or instruction concerning the use of the appliance by a person responsible for their safety. Children should be supervised to ensure that they do not play with the appliance.

PACK CONTENTS

- Heater.
- Spout assembly.
- Fixing screws and plugs.
- Torx adjusting tool.
- Installation and User Instructions.

1.0 INTERNAL COMPONENTS

- 1.1 A pressure relief device (PRD) is designed into the handwash appliance, which complies with European standards. The PRD provides a level of appliance protection should an excessive build-up of pressure occur within the appliance.
- 1.2 **DO NOT** operate the handwash with a damaged spout or blocked sprayplate, which can cause the PRD to operate.

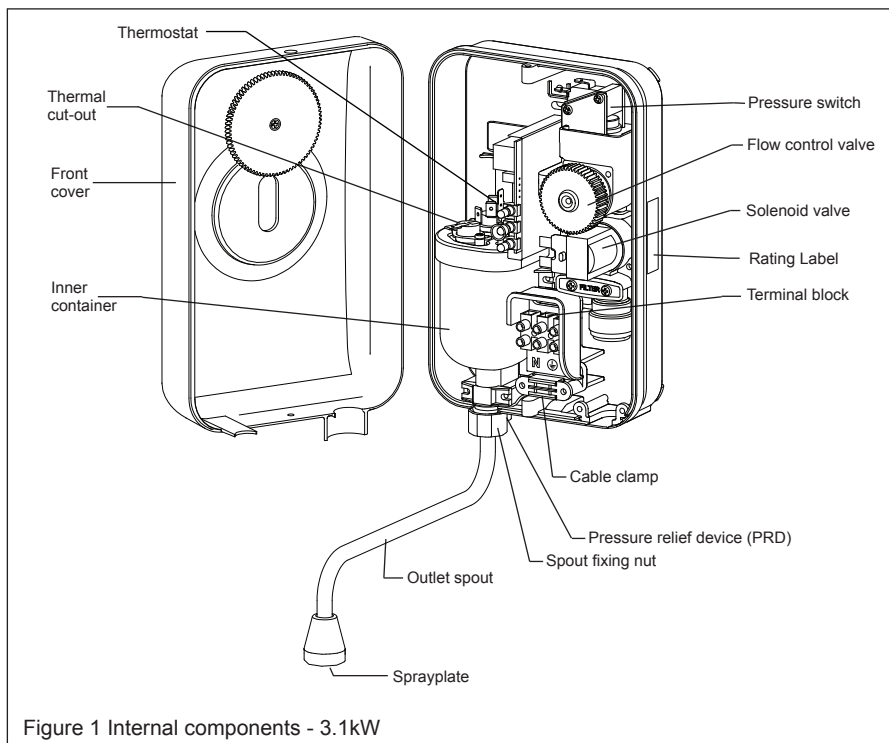

2.0 SAFETY

IMPORTANT INFORMATION

- 2.1 Products manufactured by Heatrae Sadia are to British and European Standards. These appliances are safe and without risk, provided they are installed, used and maintained in good working order in accordance with our instructions and recommendations.
- 2.2 Please read and understand these instructions before starting work and retain them for later use.
- 2.3 **DO NOT** operate the appliance if it is frozen, or suspected of being frozen. See fault finding table.

- 2.4 DO NOT operate the appliance if:
1. Water ceases to flow during use.
 2. Water has entered inside the appliance because of an incorrectly fitted cover.
 3. If the appliance is damaged.
- 2.5 ISOLATE the electrical and water supplies before removing the cover.
- 2.6 ISOLATE the electrical and water supplies BEFORE proceeding with installation or servicing.
- 2.7 The appliance must be mounted on to a flat finished wall surface that covers the full width and length of the backplate (or on top of the tiles).
- 2.8 DO NOT tile up to the appliance after fixing to the wall.
- 2.9 The sprayplate must be cleaned when any of its holes become blocked, otherwise restriction to the flow from the outlet spout will result in higher temperatures and could also cause the pressure relief device in the appliance to operate - see 1.1 and 10.2.
- 2.10 The appliance is NOT SUITABLE for mounting into steam rooms or steam cubicles.
- 2.11 The installation must be carried out in accordance with the relevant requirements of:
- The appropriate Building Regulations either The Building Regulations, The Building Regulations (Scotland) or Building Regulations (Northern Ireland).
 - The Water Fittings Regulations or Water Byelaws in Scotland.

CAUTION

- 2.12 It is recommended that persons who may have difficulty understanding or operating the controls should not be left unattended whilst washing hands. Special consideration should be given to young children and persons with reduced physical, sensory or mental capabilities.
- 2.13 Only use designated entry points for cable and pipe.
- ### **PLUMBING**
- 2.14 The plumbing installation must comply with Water Regulations.
- 2.15 The supply pipe must be flushed to clear debris before connecting to the handwash appliance.
- 2.16 DO NOT solder pipes or fittings within 300mm once the pipework is located in the appliance, as heat transfer can damage components.
- 2.17 DO NOT fit any form of outlet flow control, as the outlet acts as a vent for the heater can.
- 2.18 DO NOT use excessive force when fitting the spout fixing nut, finger tightness is sufficient.
- 2.19 All plumbing connections must be completed and checked for leaks before making the electrical connections.

ELECTRICAL

- 2.20 Before fitting the appliance, ensure that the consumer unit and any switches are suitable for the additional load. If in doubt, contact your electricity supplier or a qualified electrician.
- 2.21 The installation must comply with BS 7671 'Requirements for electrical installations' (IEE Wiring Regulations).

CAUTION

- 2.22 This appliance must be earthed.
- 2.23 Fuses do not give personal protection against electric shock. **To enhance electrical safety a 30mA residual current device (RCD) should be installed in all electric handwash circuits.** This may be part of the consumer unit, or a separate unit.
- 2.24 Ensure that all terminal block connections are sufficiently tight.
- 2.25 Switch off appliance immediately and isolate if water ceases to flow during use.
- 2.26 Other electrical equipment e.g. extractor fans, must not be connected to the handwash or its supply circuit.

3.0 TECHNICAL SPECIFICATIONS

3.1 CONNECTIONS

Inlet connection -15mm ext. diameter (copper or push fit stem elbow)
Water entry point - bottom and rear
Cable entry point - bottom and rear

3.2 ELECTRICAL

Model numbers

3.1kW - Handwash - 95 020 115

Nominal Power Rating

Model	240V	230V	Minimum cable size
3.1kW	3.1kW 12.9 amp	2.9kW 12.4 amp	1.5mm ²

3.3 MATERIALS

Backplate, cover and control knob- ABS
Element(s) - Copper sheathed rod type.

3.4 DIMENSIONS

Height - 235mm
Width - 151mm
Depth - 85mm

3.5 STANDARDS AND APPROVALS

Complies with the requirement of EN 60335-2-35.
British Electrotechnical Approvals Board (BEAB) approved.
Complies with European Community Directives (CE).
Complies with uk water regulations, kiwa approved.

4.0 SITE REQUIREMENTS

WARNING

- 4.1 The handwash must not be positioned where it will **be** subjected to freezing conditions.

WATER REQUIREMENTS

- 4.2 The installation must be in accordance with Water Regulations. To ensure activation of the heating elements, the handwash must be connected to a mains water supply with a minimum running pressure of 0.1 MPa (1 bar) and a maximum static pressure of 0.7 MPa (7 bar). If static pressure exceeds 0.7MPa (7 bar) fit a pressure reducing valve to avoid damaging the appliance. If in doubt, the pressure should be checked taking account of other services from the same water supply which could cause the pressure to fall below the minimum. The water supply can also be taken from a cold water storage cistern provided there is a minimum head of 10m above the appliance.
- 4.3 If the handwash is operated outside of the stated pressure parameters, it may not be possible to achieve optimum performance from the appliance throughout the year.

ELECTRICAL REQUIREMENTS

WARNING

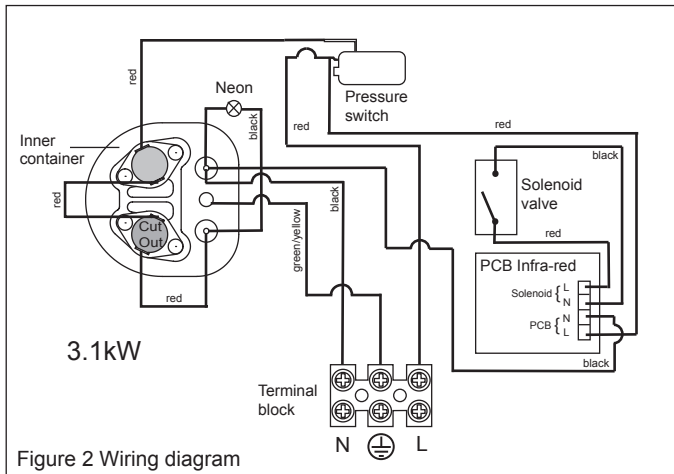

- 4.4 The appliance must be earthed**
IMPORTANT - INSTALLATION TO BE DONE BY A COMPETENT INSTALLER
- 4.5 The installation supply cable and circuit protection must conform to BS 7671.
- 4.6 Before making any sort of electrical connection, ensure that no terminal within the circuit is live. In any doubt SWITCH OFF the whole installation at the consumer unit.
- 4.7 The handwash must only be connected to a 230-240V ac supply.
- 4.8 The earthing and protective conductor arrangement within the property, in particular the supplementary bonding in the room containing the handwash, must comply with BS 7671.
- 4.9 Ensure that the supply cable and fuse are sufficient for the rated input of your appliance. Please refer to the rating label on the appliance.
- 4.10 **For a 3.1kW appliance:**
A minimum heat resistant cable size of 1.5mm² should be used. The handwash can be connected in two different ways.
1. Via a fused and switched connection appliance taken as a spur from a 13amp ring main.
 2. As a separate circuit taken directly from a spare way in a consumer unit.

In each case a double pole isolating switch having a contact separation of at least 3mm in each pole, and a minimum rating of 13amp must be incorporated in the wiring of the appliance.

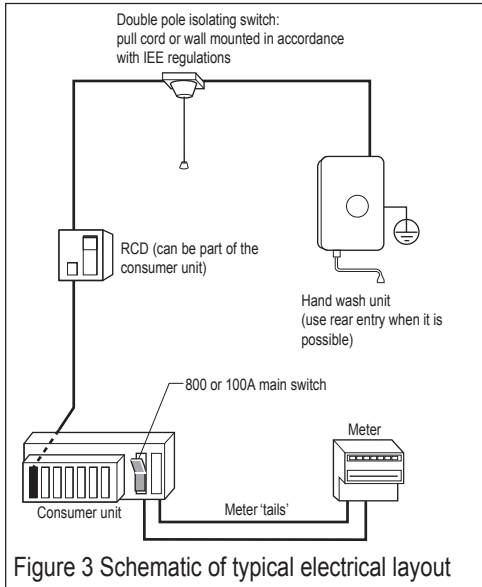

- 4.11 To obtain full advantage of the power provided by the handwash, use the shortest cable route possible from the consumer unit to the handwash.
- 4.12 If your consumer unit has a rating below 80A or if there is no spare fuse way, then the installation will not be straightforward and may require a new consumer unit. A qualified electrician should install the new consumer unit. It may be necessary to contact your electrical supplier to upgrade your supply.

CAUTION

- 4.13 To enhance electrical safety a 30mA residual current device (RCD) should be installed in all electric handwash circuits. This may be part of the consumer unit or a separate unit. **DO NOT** use a rewirable fuse, instead use a suitably rated miniature circuit breaker (MCB) or cartridge fuse. The handwash must be connected to its own independent electrical circuit.

5.0 CONSIDERATIONS BEFORE FITTING

IMPORTANT - INSTALLATION TO BE DONE BY A COMPETENT INSTALLER

- 5.1 The appliance must be mounted on a flat surface, which covers the full width and length of the backplate. It is important that the wall surface is flat otherwise difficulty may be encountered when fitting the cover.
- 5.2 Ensure that the handwash is positioned over the basin, because if the PRD operates, water will eject from the bottom of the appliance.
- 5.3 The outlet of the handwash acts as a vent and **MUST NOT** be connected to any form of outlet flow control, or any other fitting not recommended by Heatrae Sadia.
- 5.4 **DO NOT** fit the handwash to the wall and tile up to the case. It must be fitted **on to a finished flat and even wall surface**. This allows removal for servicing.
- 5.5 Position the appliance above the basin so that the spray will be contained within the basin and at a convenient height for hand washing see Figure 4.
- 5.6 A clearance of at least 130mm above and below the appliance should be allowed for access to the cover screws.
- 5.7 Cable entry can be from the rear (preferred) or from the bottom. The backplate has a cut-out position to suit size of cable. When opting for bottom entry make the cut-out to suit the cable before fitting the backplate to the wall -see Figure 5.

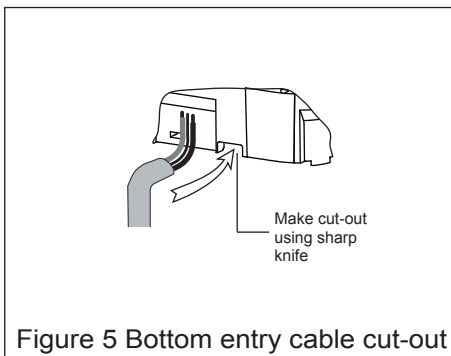
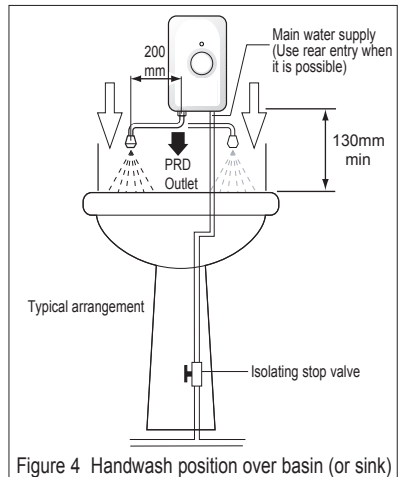

PIPE ENTRY

- 5.8 Plumbing entry can be from the rear (preferred) or from the bottom. The backplate has a cut-out position to suit 15mm pipe. When opting for bottom entry make cut-out before fitting backplate to the wall - see Figure 6.

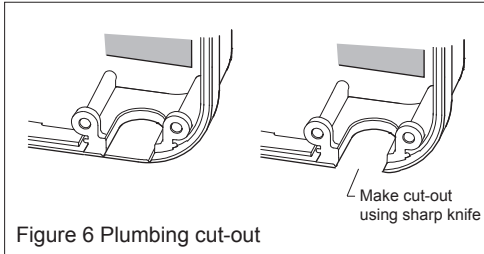

6.0 FITTING INSTRUCTIONS

- 6.1 **TURN OFF** water and electrical supply.
- 6.2 The appliance is designed for bottom and rear entries of water and electric cable. **It is advised to use the rear entry (when it is possible), in order to obtain a neater installation.**
- 6.3 Unscrew the retaining screws and lift the cover from the back plate - see Figure 7.

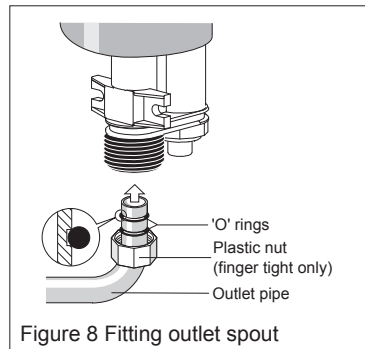
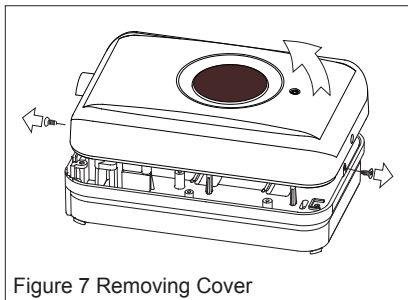

- 6.4 Fit the outlet spout - **DO NOT** over tighten, finger tight will be sufficient - see Figure 8.
- 6.5 After choosing the correct site for the handwash, use the backplate as a template and mark the two fixing holes - see 5.1 to 5.7.
BEWARE OF CABLES AND PIPES WHICH MAY BE BURIED IN THE WALL.
- 6.6 Drill holes using a 6.5mm diameter masonry drill.
- 6.7 Use plugs to suit the wall and use the fixing screws supplied.

PIPE CONNECTION

- 6.8 The handwash has been designed for a 15mm water pipe using the pushfit connection - see Figure 11 on page 12.
- 6.9 Decide where to connect the cold water mains feed to the handwash. Ensure that the pipe you have selected is not a gas pipe or a hot water pipe. Chrome and stainless steel pipe is not recommended.

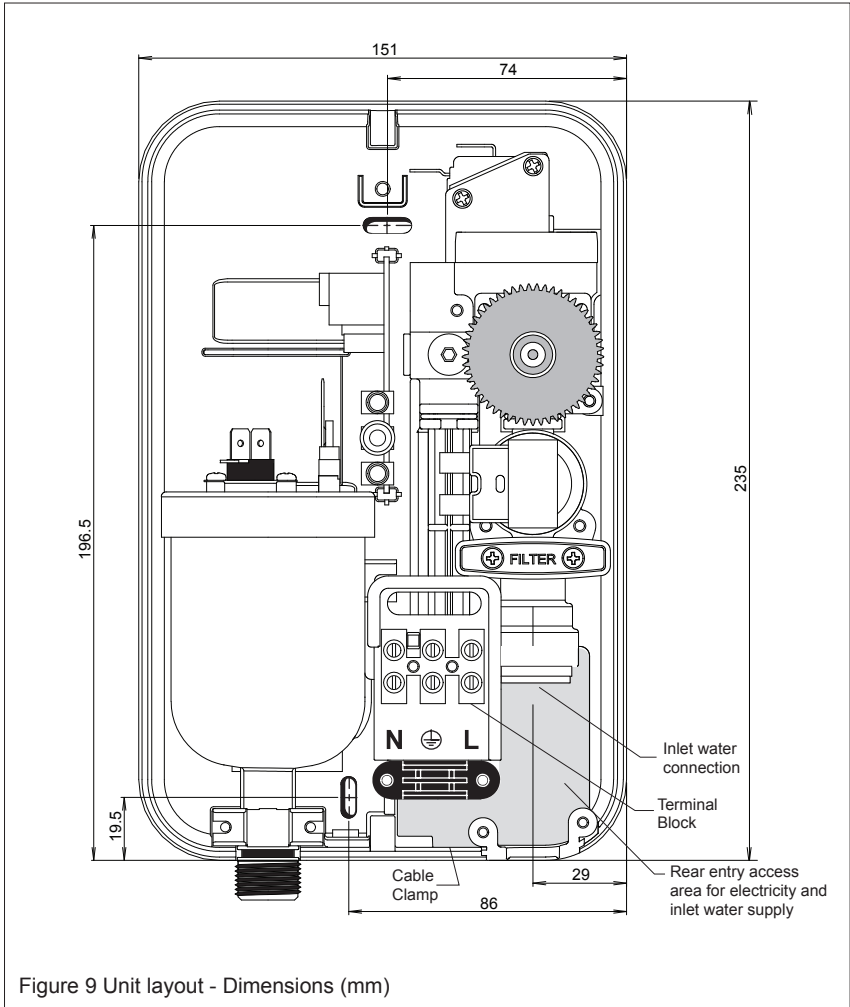
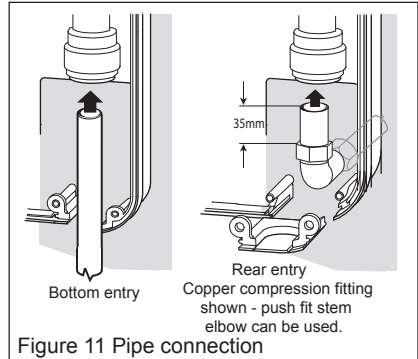
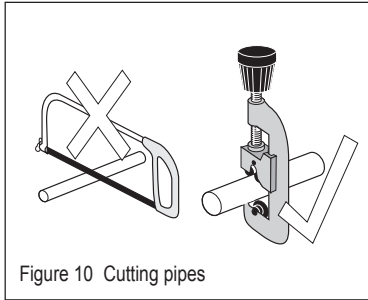
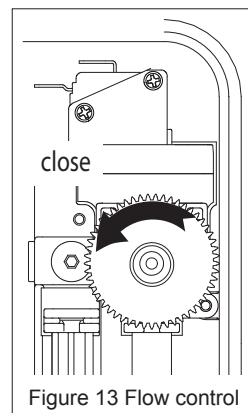
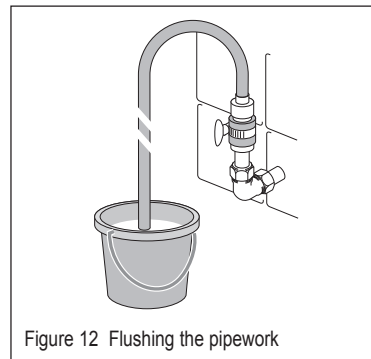

Figure 9 Unit layout - Dimensions (mm)

- 6.10 An isolating stopvalve MUST be incorporated to the main water supply to comply with Water Regulations - see Figure 4.
- 6.11 Cut all necessary pipework to length with a pipecutter and not a hacksaw. This will minimise the swarf and prevent damage to the sealing o-ring in the pushfit fitting - see Figure 10.



- 6.12 Assemble the installation before making any soldered joints to ensure that the pipe is the correct length. DO NOT use jointing compounds on any pipe fittings for the installation.
- 6.13 Remove the unit before soldering the connections.
- 6.14 It is essential to flush the pipe in order to clear debris, particles of solder and swarf - see Figure 12.
- 6.15 Turn the water off after flushing using the isolating stop valve.
- 6.16 Connect the cold water supply pipe to the inlet of the handwash, this is a push fit - see Figure 11.
- 6.17 Fit top and bottom screws and secure the backplate to the wall ensuring that it is level.
- 6.18 Close the handwash flow control valve by turning the gear fully anti-clockwise.
- 6.19 Turn the isolating stop valve on slowly and check for leaks in all pipework, rectify as necessary.
- 6.20 Turn off the isolating stop valve.



7.0 ELECTRICAL CONNECTIONS

WARNING

7.1 This appliance must be earthed.

CAUTION

- 7.2 When working on electrical components ensure they are NOT LIVE. If in any doubt, SWITCH OFF THE ELECTRICITY SUPPLY.
- 7.3 A double-pole isolating switch having a contact separation of 3mm in each pole **MUST** be incorporated to the circuit - see paragraphs 4.10 and 4.11.
- 7.4 The cable entry should be decided before fitting the backplate - see 5.7.
- 7.5 Remove the screws and clamping bar from the cable clamp - see Figure 14.
- 7.6 Feed the cable in the backplate (unscrew backplate for easy feeding if necessary).
- 7.7 Strip the outer sheath of the cable to a point about 5mm above the clamp, **thus ensuring that the cable is clamped across its outer sheath.**
- 7.8 Strip the insulation from the cores and make connections - see Figure 14.

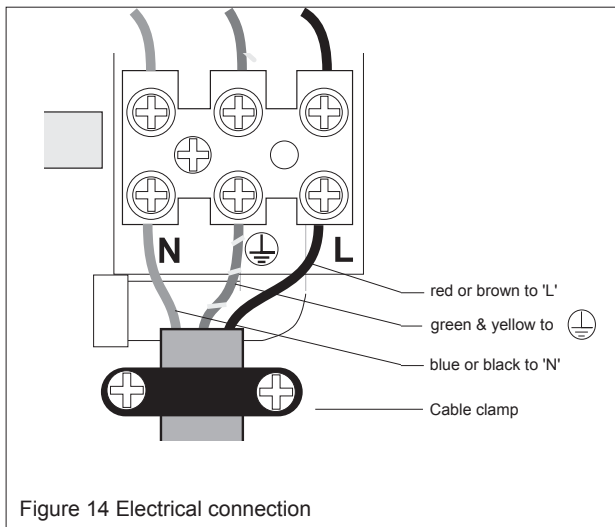

- 7.9 Make sure that all the terminal block screws are sufficiently tight.
- 7.10 Refit the clamp bar.

FITTING COVER

- 7.11 Fit outlet spout - see 6.4.
- 7.12 Place the cover onto the backplate.
- 7.13 Secure the cover to backplate using screws provided.

8.0 COMMISSIONING

NOTE: The first operation of the handwash is intended to ensure the heater unit contains water before the appliance is switched on.

- 8.1 Before turning on the electricity and mains water to the hand wash, ensure the torx adjusting screw is turned fully anticlockwise - see figure 15.
- 8.2 Turn on the electrical supply and main water supply at the isolating stop valve.
- 8.3 Place hand in front of appliance sensor to activate solenoid.
- 8.4 When water flows constantly from spout turn torx adjusting screw to an acceptable level of flow, appliance will then start to heat water. (You may have to place your hand in front of sensor to keep water flowing) adjust further for acceptable heat.
- 8.5 Leave torx adjusting key with customer.

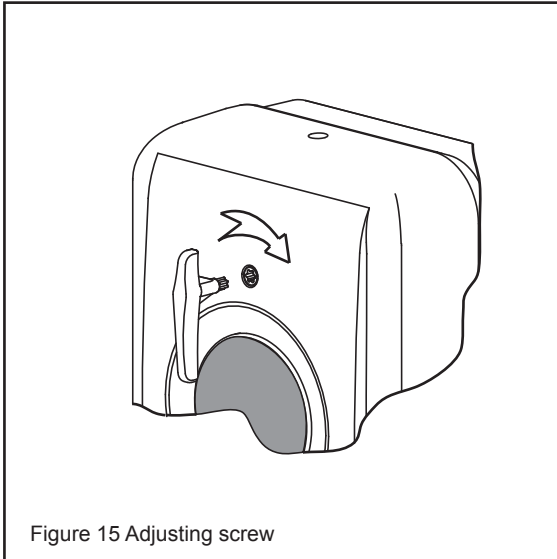

Figure 15 Adjusting screw

9.0 FAULT FINDING

- 9.1 In the unlikely event of a problem, consult the trouble-shooting chart below.
- 9.2 If you are unable to remedy the problem, CONTACT YOUR INSTALLER in the first instance.

IMPORTANT

- 9.3 Do not attempt any electrical or plumbing work unless you are competent to do so.
- 9.4 If you still cannot solve the problem, please contact Heatrae Sadia.

INSPECTION

- 9.5 It is advisable that, in the interests of safety, the handwash and its electrical installation is checked by a competent electrician, at least every two years.

Fault Finding Table

SYMPTOM	POSSIBLE CAUSE	REMEDY
1. No water flows with valve open	A. Water supply turned off	Turn on water supply
	B. Unit frozen	Turn OFF ELECTRICITY at isolating switch and contact installer. DO NOT USE THE HANDWASH.
	C. Spout blocked	Clean sprayplate - see 10.2
	D. Filter blocked	Clean filter
	E. Electrical power to appliance off	Ensure that the electricity supply to the appliance is switched on
2. Water too cold	A. Torx adjusting screw at wrong setting	Turn torx screw clockwise until temperature is comfortable
	B. Water flow too high	Turn torx screw clockwise until temperature is comfortable
	C. Poor flow	Check inlet pressure
3. Water too hot	A. Torx adjusting screw at wrong setting	Turn torx screw fully anticlockwise to increase flow and lower temperature
	B. Spout partially blocked	Clean sprayplate - see 10.2
	C. Isolating valve not fully open	Open isolating valve
	D. Filter blocked	Clean filter
4. Water runs from pressure relief device	A. Spout blocked	Clean sprayplate - see 10.2 Push plastic plunger up and back in place.
	B. Spout not blocked	Call a service engineer, as there may be a problem with internal parts.

10.0 MAINTENANCE

10.1 It is recommended that the handwash casing be cleaned using a soft cloth and that the use of abrasive or solvent cleaning fluids be avoided. It is advisable that before cleaning, the isolating switch is turned off, thus avoiding accidental operation of the handwash.

IMPORTANT

10.2 IT IS MOST IMPORTANT TO KEEP THE SPRAYPLATE CLEAN IN ORDER TO MAINTAIN THE PERFORMANCE OF THE HANDWASH. The hardness of the water will determine the frequency of cleaning.

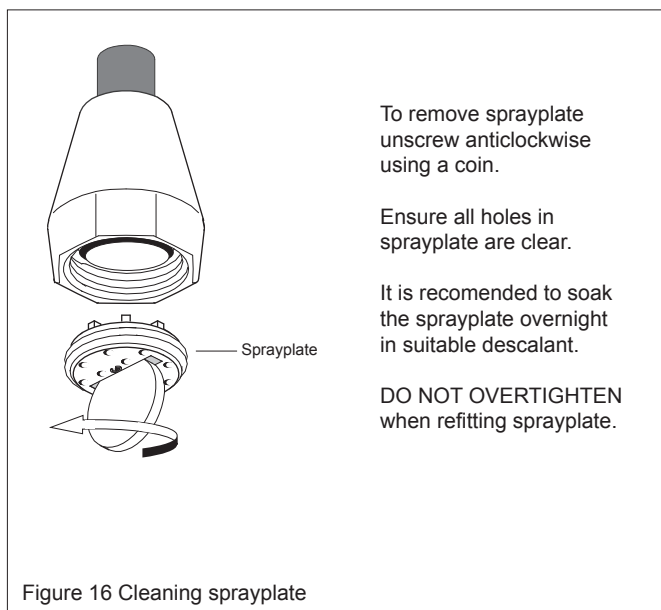

11.0 SPARE PARTS

The following comprehensive list of spare parts is available for your Heatrae Sadia handwash. Please refer to the rating label on the side of your heater before ordering, to ensure the correct spare part is obtained.

DO NOT REPLACE WITH PARTS NOT RECOMMENDED BY HEATRAE SADIA, AS THIS WILL INVALIDATE YOUR GUARANTEE AND MAY RENDER THE INSTALLATION DANGEROUS.

DESCRIPTION	CODE NO.
Heat Exchanger Assembly 3.1kW.....	95 608 003
Spout-3.1kW.....	95 604 002
Cut-out - 3.1kW.....	95 612 029
Cut-out - 3.1kW (one shot).....	95 612 031
Valve/Pressure Switch Assembly - 3.1kW.....	95 605 052
Cover Assembly.....	95 614 092
Neon Assembly - 3.1kW No-touch.....	95 615 056
Micro Switch.....	95 613 003
Filter.....	95 607 107
Pressure Relief Device.....	95 607 108
PCB.....	95 615 024
Solenoid Valve.....	95 605 058
Torx Adjustor.....	95 607 037

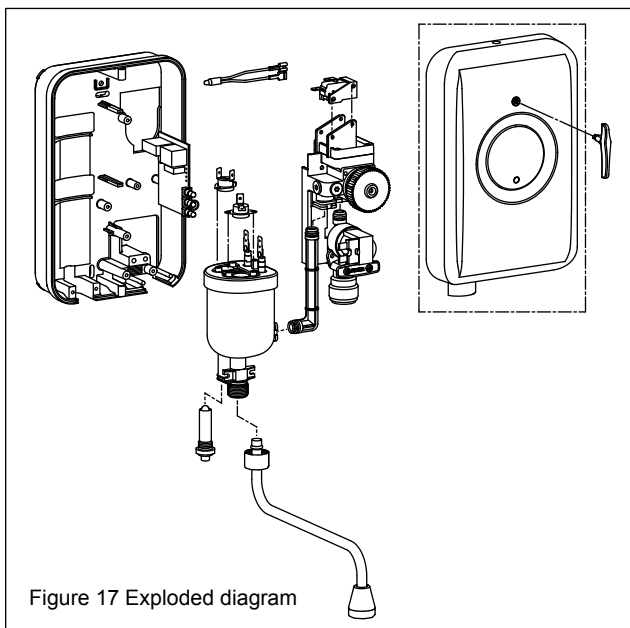

Figure 17 Exploded diagram

Guarantee & Service Policy

This product is guaranteed against faulty materials and manufacture for a period of two years from the date of purchase provided that:

- 1 The appliance has been installed by a competent person in accordance with the Installation, User Instructions, all relevant Codes of Practice, Regulations in force at the time of Installation and that all necessary controls and safety valves have been fitted correctly.
- 2 Any valves and controls are of the Heatrae Sadia recommended type and specification.
- 3 The appliance has not been modified or tampered with in any way, and has been regularly maintained as detailed in the Installation and User Instructions.
- 4 The appliance has been used only for heating potable water.

The appliance is not guaranteed against damage by frost, and the inner container with integral heating element is not guaranteed against excessive scale build-up.

This guarantee in no way affects the statutory rights of the consumer.

The policy of Heatrae Sadia is one of continuous product development and, as such, we reserve the right to change specifications without notice.

Environmental Information

Heatrae Sadia products are manufactured from many recyclable materials. At the end of their useful life they should be disposed of at a Local Authority Recycling Centre in order to realise the full environmental benefits.

Notes:

Spares Stockists

Electric Water Heating Co.
2 Horsecroft Place, Pinnacles
Harlow, Essex, CM19 5BT
Tel: 0845 0553811
E-Mail: sales@ewh.co.uk

SPD
Units 9 & 10 Hexagon Business Centre
Springfield Road, Hayes
Middlesex, UB40 0TY
Tel: 020 8606 3567

Parts Center
Tel: 0845 270 9801
www.partscenter.co.uk

Newey & Eyre
Specialist Products Division
Please contact your local branch

UK Spares Ltd.
Tower Lane, Warmley
Bristol, BS30 8XT
Tel: 0117 961 6670

William Wilson Ltd.
Unit 3A, 780 South Street
Whiteinch, Glasgow, G14 OSY
Tel: 0141 434 1530

HEATRAE SADIA

The quality name in water heating

Hurricane Way, Norwich, NR6 6EA
www.heatraesadia.co.uk
Tel: 01603 420100

A division of BAXI GROUP
© 2008

Switchboard:	01603 420100
Sales:	08700 603262
Sales Fax:	08700 600403
Service:	08701 600125
Service Fax:	08701 600181
Service Email:	heatraesadiaservice@heateam.co.uk

36006009 issue 2