

# HEATRAESADIA

SMARTER | CLEANER | WARMER

Express 50 Litres

Installation, operation and maintenance manual

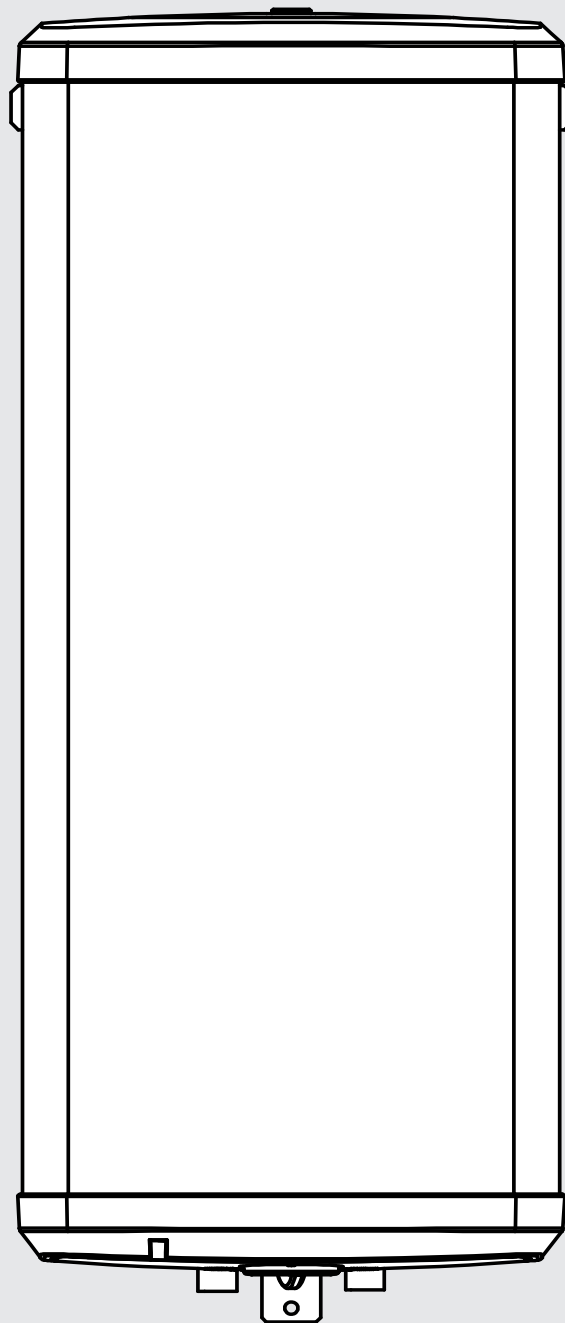

# Contents

<b>1. Introduction .....</b>	<b>3</b>
1.1 General.....	3
1.2 Symbols used.....	3
1.3 Liabilities.....	3
<b>2. Safety.....</b>	<b>4</b>
2.1 General safety warnings.....	4
2.2 Recommendations .....	4
2.3 Specific safety instructions .....	4
<b>3. Technical specifications .....</b>	<b>5</b>
3.1 Technical data .....	5
3.2 Dimensions and connections .....	6
3.3 Electrical diagram(s).....	7
<b>4. Description of the product .....</b>	<b>8</b>
4.1 General description .....	8
4.2 Operation principle .....	8
4.3 Main components .....	8
4.4 Standard delivery .....	8
<b>5. Before installation .....</b>	<b>9</b>
5.1 Installation regulations.....	9
5.2 Installation requirements .....	9
5.3 Choice of location.....	9
5.4 Transport .....	9
<b>6. Installation .....</b>	<b>10</b>
6.1 General.....	10
6.2 Water connections.....	11
6.3 Electrical connections.....	13
<b>7. Commissioning .....</b>	<b>13</b>
7.1 General.....	13
7.2 Checklist before commissioning.....	13
7.3 Commissioning procedure.....	13
<b>8. Operation .....</b>	<b>14</b>
8.1 General.....	14
<b>9. Maintenance.....</b>	<b>15</b>
9.1 Standard inspection & maintenance operations.....	15
<b>10. Troubleshooting .....</b>	<b>16</b>
10.1 Fault finding.....	16
<b>11. Warranty .....</b>	<b>17</b>
11.1 General.....	17
11.2 Warranty conditions.....	17
11.3 Water supply requirements.....	17
11.4 Claims under warranty.....	17
11.5 Exclusions .....	17
<b>12. Decommissioning .....</b>	<b>18</b>
12.1 Decommissioning procedure.....	18
<b>13. Spare parts.....</b>	<b>20</b>
13.1 Spare parts list .....	21

# 1. Introduction

## 1.1 General

The following instructions are offered as a guide to the user and installer. The installation must be carried out by a competent plumbing and electrical installer in accordance with:

- ▶ Building Regulations Part G and L
- ▶ The Building Standards (Scotland) Regulations
- ▶ The Building Regulations (Northern Ireland)
- ▶ I.E.E Wiring Regulations
- ▶ UK Water Regulations

## 1.2 Symbols used

In these instructions, various risk levels are employed to draw the user's attention to particular information. In doing so we wish to safeguard the user, avoid hazards and guarantee the correct operation of the appliance.



### DANGER

Risk of a dangerous situation causing serious physical injury.



### WARNING

Risk of dangerous situation causing slight physical injury.



### CAUTION

Risk of material damage.



Signals important information.

## 1.3 Liabilities

### Manufacturers liability

Our products are manufactured in compliance with the requirements of the various applicable European Directives.

This appliance complies with the requirements of the CE marking directive and is Kiwa approved to show compliance with Building Regulations (Part G, section G3).

In the interest of UK customers, we are continuously endeavouring to make improvements in product quality. All the specifications stated in this document are therefore subject to change without notice.

Our liability as the manufacturer may not be invoked in the following cases:

- ▶ Failure to abide by the instructions for using the appliance.
- ▶ Faulty or insufficient maintenance of the appliance.
- ▶ Failure to abide by the instructions for installing the product.

### Installer's liability

The installer is responsible for the installation and the commissioning of the appliance. The installer must respect the following instructions:

- ▶ Read and follow the instructions given in the manual provided with the appliance.
- ▶ Carry out installation in compliance with the prevailing legislation and standards.
- ▶ Perform the initial start up and carry out any checks necessary.
- ▶ Explain the installation to the user.
- ▶ If maintenance is necessary, warn the user of the obligation to check the appliance and maintain it in good working order.
- ▶ Give the instruction manual to the user.
- ▶ Complete the warranty registration card.

### Users liability

To guarantee optimum operation of the appliance, the user must respect the following instructions:

- ▶ Read and follow the instructions given in the manual provided with the appliance.
- ▶ Call on qualified professionals to carry out installation and initial start up.
- ▶ Ask your installer to explain your installation to you.
- ▶ Have your required checks and services done.
- ▶ Keep the instruction manuals in good condition and available for future reference.



This appliance can be used by children aged from 8 years and above and persons with reduced physical sensory or mental capabilities or lack of experience and knowledge if they have been given supervision or instruction concerning use of the appliance in a safe way and understand the hazards involved. Children shall not play with the appliance. Cleaning and user maintenance shall not be made by children without supervision.

Children must be supervised to ensure they do not play with the appliance.

 Do not connect any pressure-relief device to the vent pipe of this water heater.

How hot water can be drained. (see page 11 for more details).

 If the supply cord is damaged, it must be replaced by the manufacturer, its service agent or similarly qualified persons in order to avoid a hazard.

## 2. Safety

### 2.1 General safety warnings



#### WARNING

- ▶ Only competent persons having received adequate training are permitted to work on the appliance and the installation.
- ▶ Do not tamper with any of the safety valves or controls supplied with the appliance.
- ▶ Before any work, switch off the mains supply to the appliance.



#### CAUTION

Do not operate the immersion heater until the appliance has been filled with water.



#### WARNING

When handling the appliance, take appropriate precautions for the weight of the appliance. Weights can be found in section 3, p5.



#### CAUTION

Annual maintenance is recommended to be carried out by a competent person, see section 9, page 15.

### 2.2 Recommendations



#### WARNING

- ▶ Install only as a CISTERN FED appliance, failure to do so will invalidate any guarantee and may lead to a dangerous installation.

#### CISTERN FED INSTALLATION

- ▶ When installed as a Cistern Fed water heater the cold water supply must be from a feed cistern complying with Water Regulations Schedule 2, section 7, paragraph 16.
- ▶ A vent pipe must be connected to the vented top of the heater. The vent pipe must rise continuously and be arranged to discharge into the cold water feed cistern.
- ▶ The vent pipe must have a minimum bore of 19mm.
- ▶ More than one conventional tap can be supplied.

### 2.3 Specific safety instructions



#### WARNING

- ▶ This appliance is supplied with a factory temperature setting of 54 C for optimum energy efficiency. However, in some applications to aid in the control of legionella it may be necessary to reset this to a higher temperature. It is the responsibility of the installer and end user to ensure that where applicable the requirements of the "Approved Code of Practice L8: The control of legionella bacteria in water systems" are met.

### 3. Technical specifications

#### 3.1 Technical data

<b>Product Name</b>	<b>Express 50L V 3kW</b>
<b>Product Code</b>	7037070
<b>Electrical rating</b>	3.0kW @ 240V ~ / 2.8kW @ 230V ~
<b>Weight Empty kg</b>	21
<b>Weight Full kg</b>	71
<b>Capacity (Litres)</b>	50
<b>Heat up time (min)</b>	65
<b>Maximum Design (Rated) pressure (Max. head pressure Cistern Fed)</b>	0.2MPa (2 bar) (20 metres)
<b>Maximum design pressure for mains fed installation</b>	1.MPa (10 bar)
<b>Minimum supply pressure</b>	0.04 MPa (0.4 bar)
<b>Insulation thickness (min)</b>	22mm

Table 1: Technical data

<b>Product Name</b>	<b>Express 50L V 3kW</b>
<b>Suppliers name or trade mark</b>	Express
<b>Supplier's model identifier</b>	50L V 3kW
<b>Storage volume V in litres</b>	50
<b>Mixed water at 40 °C V40 in litres</b>	83
<b>The declared load profile</b>	M
<b>The water heating energy efficiency class of the model</b>	C
<b>The water heating energy efficiency in %</b>	38.4
<b>The annual electricity consumption in kWh</b>	1338
<b>Daily fuel consumption <math>Q_{elec}</math> in kWh</b>	6.17
<b>The thermostat temperature setting of the water heater, as placed on the market by the supplier</b>	54°C
<b>Specific precautions that shall be taken when the water heater is assembled, installed or maintained and disposed of at end of life.</b>	See pages 3 to 21

Table 2: Technical fiche

Technical parameters in accordance with European Commission regulations 814/2013 and 812/2013

### 3.2 Dimensions and connections

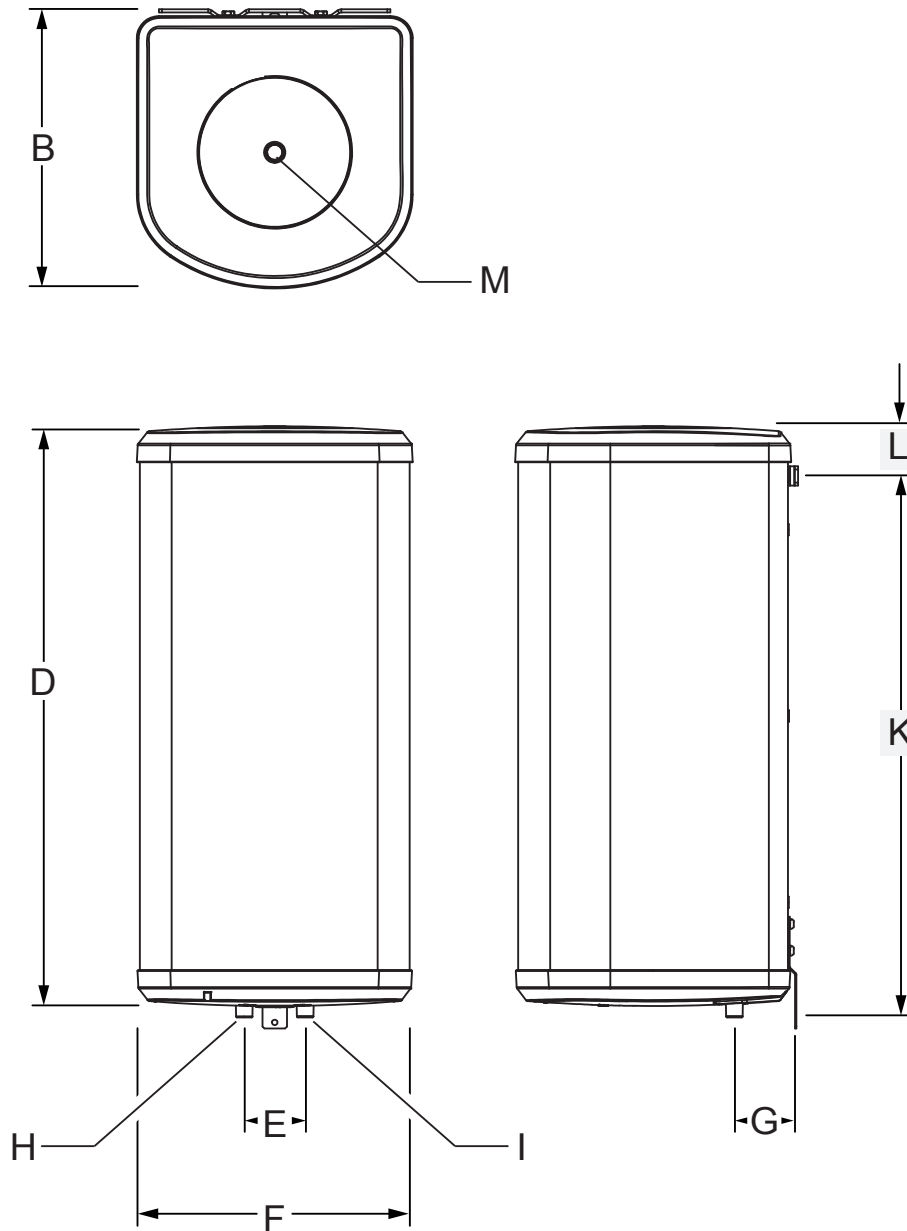

Figure 1: General dimensions

Item	50L V 3kW
B	369mm
D	903mm
E	100mm
F	371mm
G	95mm
H	OUTLET 22mm / 3/4"BSP (M)
I	INLET 22mm / 3/4"BSP (M)
K	865mm
L	131mm
M	1/2" BSP female

Table 3: General dimensions table

### 3.3 Electrical diagram(s)

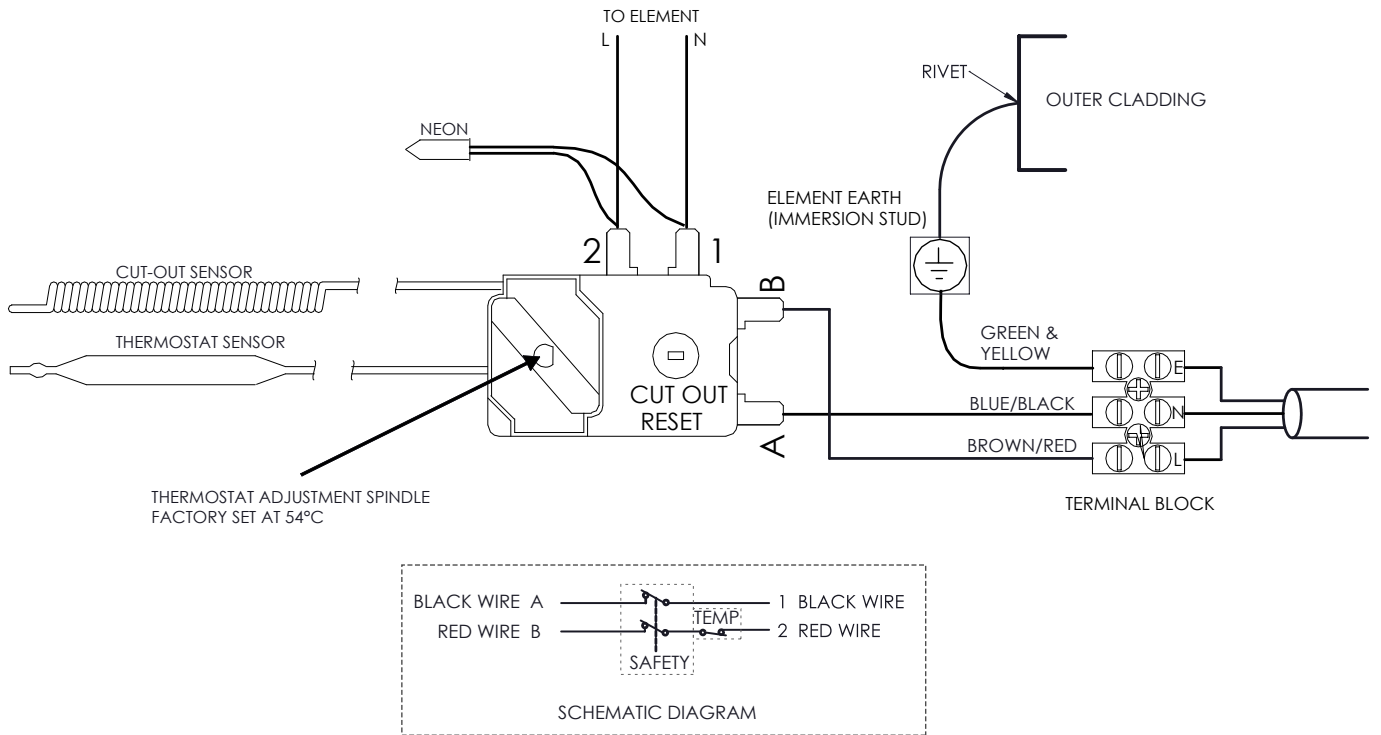

Figure 2: Wiring Diagram

## 4. Description of the product

### 4.1 General description

This appliance is a purpose designed vented water heater. The water heater has a stainless steel inner vessel, which ensures an excellent standard of corrosion resistance. The outer casing is a combination of resilient thermoplastic mouldings and coated corrosion proofed steel sheet. All products are insulated with CFC free polyurethane foam to give good heat loss protection.

### 4.2 Operation principle

The appliance is used to heat and store hot water for use in domestic & commercial applications.

The water is heated directly using a factory fitted electric heating element and thermostatically controlled by an adjustable thermostat.

This appliance is vented which means that the tank where the water is heated is vented to atmosphere and no pressure is built up in the appliance. The appliance can be installed in only one way, cistern fed.

A cistern fed appliance is fed from a cistern tank and vents back into this tank through a pipe at the top of the appliance. Multiple vented tap outlets can be used with this installation.

### 4.3 Main components

See figure 3: Main components

### 4.4 Standard delivery

The delivery includes:

- ▶ Water heater
- ▶ Wall mounting brackets
  
- ▶ Literature pack
  - ▶ Instructions
  - ▶ Warranty card

**Please check all components are supplied in the pack and advise your supplier if any are missing.**

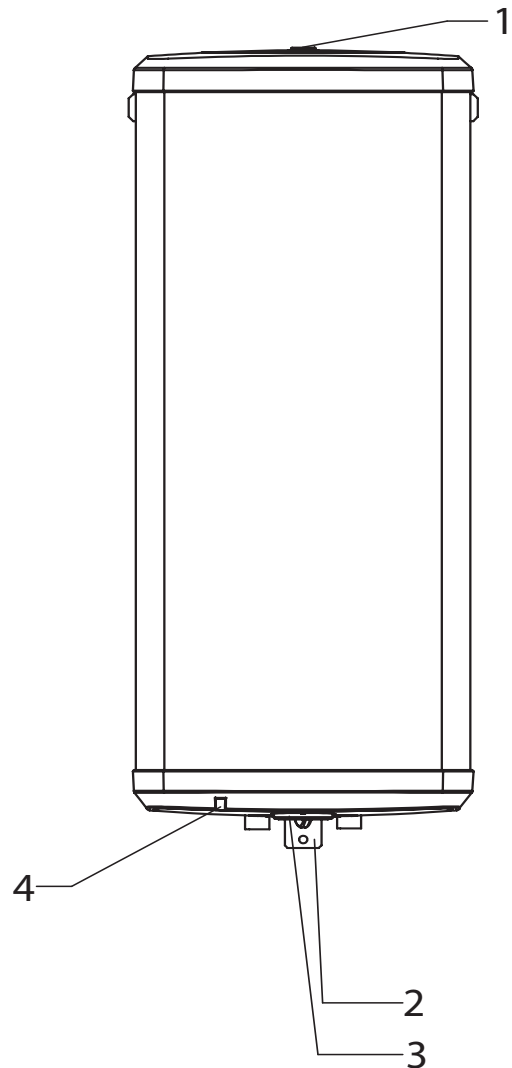

Figure 3: Main components

Item	Description
1	Vent pipe connection for cistern fed installation
2	Wall Mounting Bracket (Lower)
3	Temperature control
4	Neon indicator

Table 4: Main components table



## 5. Before installation

### 5.1 Installation regulations



#### WARNING

Installation of the appliance must be done by a qualified engineer in accordance with prevailing and national regulations as listed below.

- ▶ Building Regulations G3
- ▶ The Building Standards (Scotland)
- ▶ The Building Regulations (Northern Ireland)
- ▶ I.E.E Electrical Regulations
- ▶ UK Water Regulations

### 5.2 Installation requirements

#### Water supply

It is recommended that the maximum water demand is assessed and the water supply checked to ensure this demand can be satisfactorily met.

- ▶ We suggest the minimum supply requirements should be 0.04MPa (0.4 bar) pressure.
- ▶ A 15mm cold water supply is recommended.
- ▶ The higher the available pressure and flow rate the better the system performance.
- ▶ The appliance has a maximum operating pressure of 0.2Mpa (2 bar, 20 meters head).

#### Limitations

The appliance should not be used in association with any of the following:

- ▶ Situations where maintenance is likely to be neglected.
- ▶ Water supplies that have either inadequate pressure or where the supply may be intermittent.
- ▶ In areas where the water consistently contains a high proportion of solids.
- ▶ In areas where the water supply contains chloride levels that exceed 250mg/l.

### 5.3 Choice of location

The appliance must be vertically wall mounted. Although location is not critical, the following points should be considered:

- ▶ The appliance should be sited to ensure minimum dead leg distances, particularly to the point of most frequent use.
- ▶ Avoid siting where extreme cold temperatures will be experienced. All exposed pipe work should be insulated.
- ▶ Access to associated controls and immersion heaters must be available for the servicing and

maintenance of the system.

- ▶ Clearance under the water heater should be at least 300 mm to allow removal of the cover and immersion heater.
- ▶ Ensure that the wall the appliance is to be mounted on is capable of permanently supporting the weight when full of water (see table 1, page 5 for weights).

### 5.4 Transport

Prior to installation the appliance should be transported and stored in an upright position in its original packaging in a dry area free from excessive damp, humidity or frost.

Please take care when handling a packaged appliance. The appliances are heavy and must only be moved manually using safe working practices. The package weights are displayed on the carton label. Once the packaging has been removed decide on a safe lifting method for the appliance again taking note of the weights noted in table 1, page 5.

## 6. Installation

### 6.1 General

After reading the previous sections in this booklet and choosing a suitable location for the appliance please install, paying attention to the following water, electrical and commissioning sections.

#### Mounting the water heater

The water heater should be mounted using the brackets supplied following the steps stated below:

- ▶ The top bracket bolts will require mounting to the appliance. Note the location of the bolt holes used for the vertical appliances as well as which way up the appliance should be mounted.
- ▶ The top bracket bolts should be screwed all the way into the hole until they stop and stick out 8mm as shown in figure 4 below.
- ▶ The bottom bracket will require mounting to the casing as shown in figure 5 using the fixings supplied. This must be done before the appliance is mounted on the wall
- ▶ Secure the top bracket to the wall using appropriate fixings. Ensure it is fitted the correct way up.
- ▶ Locate the appliance top bracket bolts in the corresponding slots in the wall bracket. Ensure they are fully engaged and seat correctly (figure 4).
- ▶ Secure the bottom bracket to the wall.

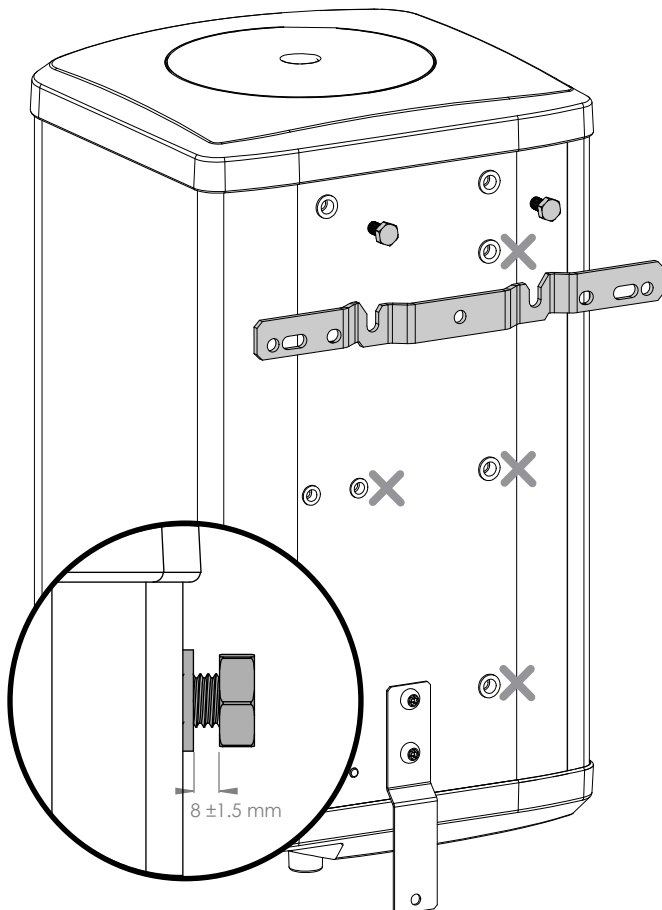

Figure 4: Top Bracket

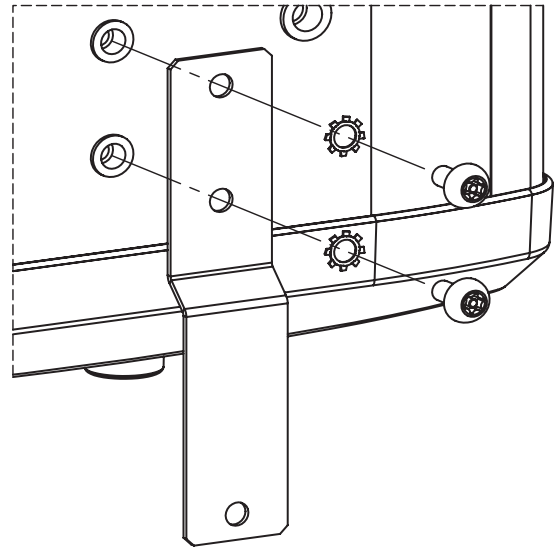

Figure 5: Bottom Bracket

## 6.2 Water connections

### PLUMBING - CISTERN FED

- ▶ This method of installation is to be used at all times when the outlet is connected to one or more conventional taps. It is not recommended for supplying a shower. Individual site demands should be considered when choosing the number of outlets to be served.
- ▶ A vent pipe must be connected to the outlet connection of the heater.
- ▶ The vent pipe must have a minimum internal diameter of 19mm.
- ▶ The vent pipe must be unobstructed, rise continuously and be arranged to discharge over the cold water feed cistern. DO NOT connect any pressure relief device to the vent pipe of this water heater.
- ▶ The cold water supply must be from a cold water feed cistern complying with Byelaw 30. The maximum head pressure must not exceed 20 metres (Water Regulations Schedule 2, section 7, paragraph 16).
- ▶ It is recommended that an WRC Listed isolating valve is fitted on the cold water supply to the heater. A drain cock should be fitted on the inlet pipe to the heater at a level lower than the appliance to allow draining for maintenance.
- ▶ The inlet must not be connected directly to the cold water mains supply.
- ▶ The Vent Pipe should be connected to the top of the heater using a 1/2" BSP connection.

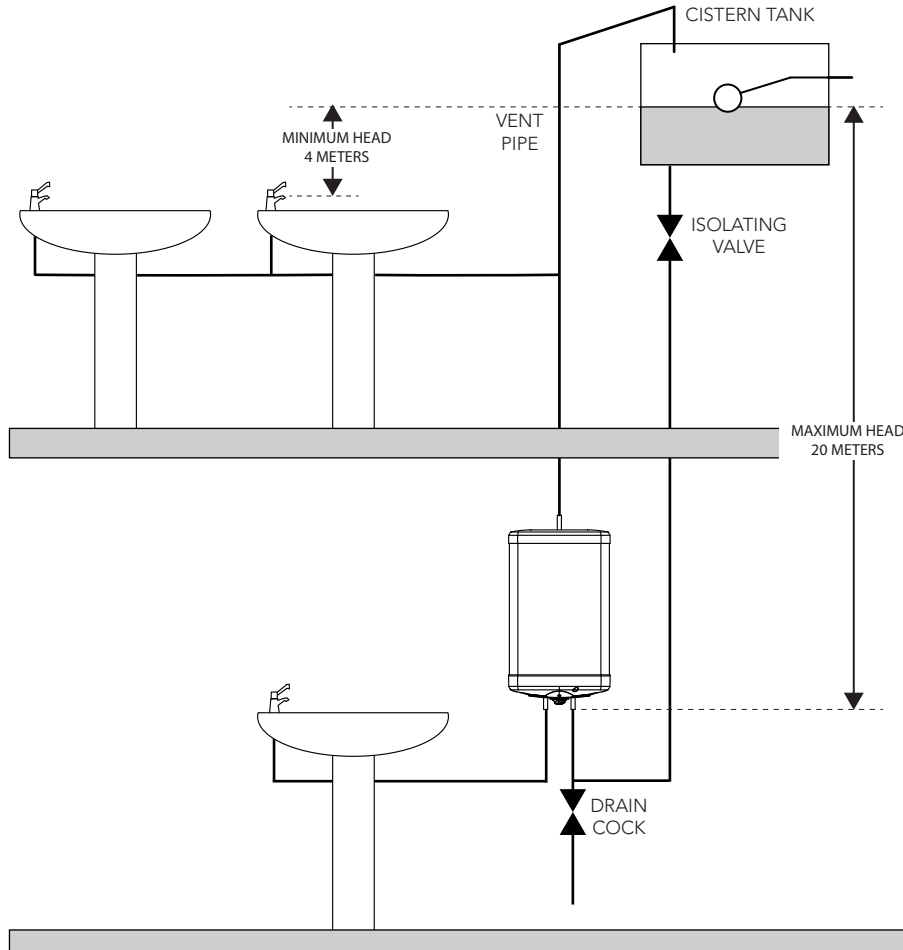

Figure 8: Typical cistern fed installation

## 6.3 Electrical connections



### WARNING

- ▶ Disconnect from the mains electrical supply before removing any covers.
- ▶ Never attempt to replace the immersion heater other than with the recommended immersion heater.
- ▶ DO NOT bypass the thermal cut-out in any circumstances. Ensure the two spade terminations on the wires from the thermostat and thermal cut-out are pushed firmly into the corresponding terminations on the element plate assembly.
- ▶ All electrical wiring should be carried out by a competent electrician and be in accordance with the latest I.E.E, Wiring Regulations.
- ▶ Each circuit must be protected by a suitable fuse and double pole isolating switch with a contact separation of at least 3mm in both poles.
- ▶ DO NOT operate the immersion heater until the appliance has been filled with water.

- ▶ Check that the electrical supply is of sufficient current rating and voltage, see Technical Data page 5.
- ▶ A 2 metre length of flexible cable is supplied factory fitted. The cable specification is H05VV-F 3G 2.5mm<sup>2</sup>. If replacing or extending the same specification of cable should be used.
- ▶ The flexible cable must be wired into an appropriately fused switched spur.
- ▶ The conductor sheaths are colour coded as follows:

Green and Yellow	EARTH	
Brown	LIVE	(L)
Blue	NEUTRAL	(N)

## 7. Commissioning

### 7.1 General



#### WARNING

DO NOT operate the immersion until the water heater has been filled with water.

### 7.2 Checklist before commissioning

- ▶ Check that all installation and vent pipe requirements have been met.
- ▶ Check all water connections are tight.
- ▶ Check all electrical connections are tight.
- ▶ Check all earth bonding links are connected, tight and un-damaged.
- ▶ Check earth continuity, short circuits, polarity and resistance to earth.

### 7.3 Commissioning procedure

#### Cistern fed installation

- ▶ Open the highest hot outlet fed by the appliance.
- ▶ Turn on the cold water supply from the cold water cistern
- ▶ Allow the appliance to fill until water discharges from the hot outlet.
- ▶ Leave running to purge air and flush pipework
- ▶ Open any other hot outlets to purge air. **8.1**



#### WARNING

- ▶ If the appliance is to be left unused following installation and commissioning e.g. unoccupied properties, the appliance should be drained or regularly flushed through with fresh mains water once a week.
- ▶ When placing the appliance into service, the procedure for filling the appliance and the system checks detailed above should be carried out.

## 8. Operation

### 8.1 General

- ▶ The appliance stores water at the temperature set on the internal adjustable thermostat. This can be set to give temperatures in the range 10°C to 70°C. The factory set temperature is set at 54°C.
- ▶ The temperature control is underneath the cover, please see figure 9, page 15 on how to remove.
- ▶ Turn the adjustment knob clockwise to set hotter, or counterclockwise to set cooler.
- ▶ In hard water areas it is advised that the maximum temperature is restricted to prevent build up of scale.
- ▶ To avoid risk of freezing when the heater is not in use for long periods during the winter months, do not switch off the electrical supply and set the thermostat to its minimum position. N.B. This will not protect other system pipework.
- ▶ The indicator light will be illuminated when the appliance is heating.
- ▶ To ensure the appliance continues to operate at its optimum performance it should be periodically maintained in accordance with the instructions given under the section headed MAINTENANCE.



#### WARNING

- ▶ DO NOT bypass the thermal cut-out in any circumstances.

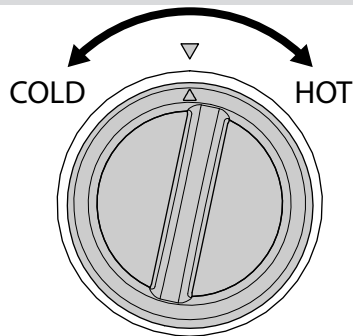

WARNING DISCONNECT THE MAINS  
SUPPLY BEFORE REMOVING THIS COVER

Figure 9: Temperature control

- ▶ To ensure the appliance continues to operate at its optimum performance it should be periodically maintained in accordance with the instructions given under the section headed MAINTENANCE.

## 9. Maintenance

### 9.1 Standard inspection & maintenance operations

To ensure the continued safe and efficient operation of the appliance, it should be regularly maintained.

Maintenance should be carried out by a competent person and any replacement parts used should be authorised Heatrae Sadia spare parts.

It is recommended that maintenance is carried out annually and should include the checks detailed in the section below.

In hard water areas the appliance will require periodic descaling to ensure efficient operation. To descale the appliance:

#### Descaling immersion heater



#### CAUTION

Be careful when removing the immersion heater as some water will be left in bottom of appliance.

DO NOT use a sharp implement as damage to the element surface could be caused.

DO NOT scrape element clean.

- ▶ Turn off the cold water supply and isolate the electrical supply to the appliance.
- ▶ Attach a hosepipe to the drain cock having sufficient length to take water to a suitable discharge point below the level of the appliance.
- ▶ Open a hot tap close to the appliance (cistern fed installations) and open drain cock to drain the appliance.
- ▶ When empty, open the cover to the immersion heater housing. Remove the securing screw then release the cover by carefully inserting a flat bladed screwdriver into the slots around the cover and gently levering outwards until the catches release (see Figure 9, page 15).
- ▶ Disconnect wiring from immersion heater terminals.
- ▶ Carefully remove the thermostat and thermal cut-out capillary sensors from the pocket on the immersion heater.
- ▶ Place a suitable receptacle beneath the immersion heater to collect any water left in the appliance.
- ▶ Unscrew immersion heater bolts and remove immersion heater from the water heater.

NOTE: Over time the immersion heater gasket may become stuck to the mating surface. To break the seal there is a separate threaded hole in the plate. Screw one of the removed bolts into this hole to help remove element.

- ▶ Carefully remove any scale from the surface of the element. Remove any loose scale from the appliance interior.
- ▶ Ensure sealing surfaces are clean and seals are undamaged, if in doubt fit a new gasket.
- ▶ Replace immersion heater ensuring correct orientation. One of the bolt holes uses a larger bolt to ensure the correct orientation.
- ▶ Tighten bolts.
- ▶ Fill appliance with water and check for leaks.
- ▶ Replace thermostat and thermal cut-out capillary sensors into pocket on the immersion heater, ensure that the thermostat is inserted first followed by the cut-out (see figure 2, page 7 to identify). Ensure they are pushed fully into the pocket and the capillary tubes are not kinked or damaged.
- ▶ Reconnect wires from the thermostat onto element, ensuring that the terminals are correctly engaged.
- ▶ Reconnect the earth wires to the earth stud.
- ▶ Refill the appliance. When water issues from the hot tap or spout allow to run for a short while to purge any air and flush through the pipework. Open successive hot taps served by the appliance to purge any air. With all hot outlets closed check all joints for leaks.
- ▶ Close immersion heater housing cover ensuring the catches are pushed fully home until they "snap" into place. Secure by replacing the screw previously removed.

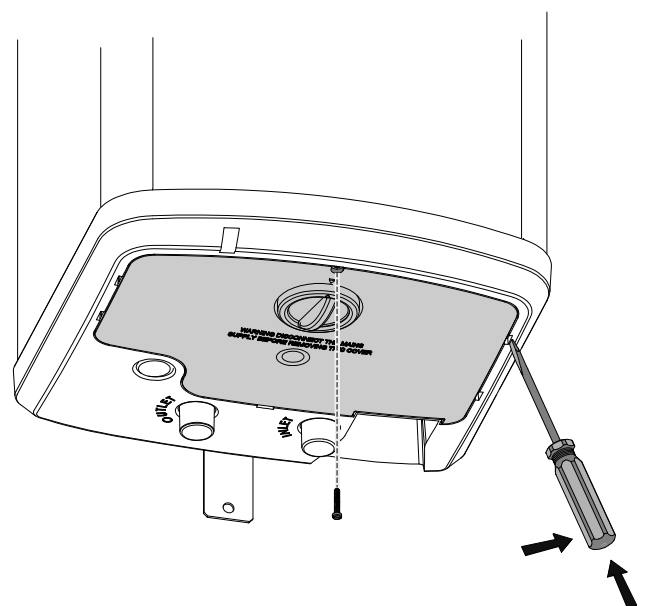

Figure 10: Cover removal

## 10. Troubleshooting



### WARNING

DO NOT tamper with any of the safety valves or controls supplied with the water heater as this will invalidate any warranty.

Water contained in the water heater may be very hot, especially following a thermal control failure. Caution must be taken when drawing water from the water heater.

## 10.1 Fault finding

### Important

- ▶ Servicing should only be carried out by competent persons in the installation and maintenance of water heating systems.
- ▶ Any spare parts used MUST be authorised parts.
- ▶ Disconnect the electrical supply before removing any electrical equipment covers.
- ▶ NEVER bypass any thermal controls.
- ▶ The Fault Finding Chart (table 5, below) will enable operational faults to be identified and their possible causes rectified.

FAULT	POSSIBLE CAUSES	ACTION
Water not heating	Electrical supply fault.	Check electrical supply.
	Thermal cut-out tripped.	Check cut-out, if operated reset and check thermostat operation. If necessary replace.
	Thermostat fault.	Check thermostat operation, replace if necessary.
	Element fault.	Check element for circuit continuity and insulation resistance. If faulty replace.
No water flow - General	Cold water supply not turned on.	Check mains water supply is on.
	Blockage in cold water supply.	Check for obstructions.
No water flow - Cistern Fed installations	Blockage in tapset.	Check for obstructions.
	Cistern tank empty.	Check water supply to cistern tank is turned on. Check operation of cistern float valve.
Water flows gradually reduces - Cistern Fed installations	Cistern not filling as fast as outlet flow rate.	Check water supply to cistern tank is turned on and that the inlet flow rate is equal to outlet flow rate. Check operation of cistern float valve.
	Vent pipe blockage.	Check vent pipe for obstructions, clear as necessary.

Table 5: Fault finding chart

### Spare Parts

A full range of spare parts are available for the appliance range (table 6, page 20). Refer to the technical data label on the appliance to identify the model installed and ensure the correct part is ordered. You will need to quote the serial number, which is printed on the data label.



# 11. Warranty

## 11.1 General

The Express warranty provides a high level of customer support and peace of mind in the unlikely event that a problem arises from a manufacturing defect. It is supported by a nationwide team of field-based engineers and our own call centre.

The warranty covers appliances installed in domestic and commercial properties for the following periods:

- ▶ Stainless steel storage vessel and connections - 2 years
- ▶ Cold water control valves supplied with the appliance - 2 years
- ▶ Immersion heater assembly - 2 years
- ▶ Electrical controls as factory fitted to the appliance - 2 years

The warranty periods apply from the date of purchase and include both parts (where supplied by Heatrae Sadia) and labour.

This warranty is valid for installations within the United Kingdom. For installations in the Republic of Ireland please contact Potterton Myson (Ireland) Limited on +353 (0) 1 4590870 for warranty terms and conditions applicable. For installations outside of the United Kingdom and the ROI please contact Heatrae Sadia Export on +44 1603 420271 for warranty terms and conditions applicable.

This warranty does not affect your statutory rights.

## 11.2 Warranty conditions

The warranty is given provided that the following conditions have been met:

- ▶ The appliance has been installed by a competent installer in accordance with the instructions contained in this manual and in compliance with all relevant laws, guidance, codes of practice and regulations in force at the time of installation.
- ▶ The appliance has not been modified or tampered with in any way, other than by Heatrae Sadia or authorised engineers.
- ▶ The appliance or any part or parts of the appliance (whether factory fitted or otherwise) have not been repaired or replaced other than by a Heatrae Sadia authorised engineer and any replacement parts used on the appliance are authorised Heatrae Sadia spare parts.
- ▶ The appliance has not been subject to damage caused by the build up of scale.
- ▶ The appliance has not been subjected to frost or freezing temperatures.
- ▶ The appliance has not been subjected to misuse or neglect.
- ▶ The appliance has not been subject to wilful or accidental damage caused by your negligence.
- ▶ Regular maintenance has been carried out by a competent person or a Heatrae Sadia authorised

engineer in accordance with the maintenance requirements set out in this manual.

- ▶ The appliance has not been installed in areas where the water supply contains chloride levels which exceed 250mg/l.
- ▶ The appliance is registered within 60 days of purchase. This can be done by telephone, online or by using the registration form supplied with the appliance.
- ▶ The appliance has not been affected by any cause beyond our reasonable control including, without limitation: an act of God, explosion, flood, fire or accident; war or civil disturbance; strike, industrial action or stoppages of work; any form of government intervention; a third party act or omission including theft or malicious damage; failure by you to give us a correct delivery address or notify us of any change of address.

## 11.3 Water supply requirements

This appliance must only be used for the storage of wholesome water. The storage of water from supplies not meeting the requirements of the Water Supply (Water Quality) Regulations will invalidate the warranty. Any disinfection procedure must be carried out in accordance with BS EN 806 and the complete system be thoroughly flushed following application of any disinfection solution.

## 11.4 Claims under warranty

In order to claim against the warranty the following should be noted:

- ▶ Defects should be reported to Heatrae Sadia as soon as you are aware of them. Please report any defect to Heatrae Sadia by contacting 0344 871 1535.
- ▶ Evidence of purchase (for example a receipt) and date of supply is submitted when making a claim.
- ▶ Access should be available, at reasonable times and upon reasonable notice, to the appliance to allow any inspection, repair or replacement.
- ▶ The appliance should not be removed from its place of installation so a Heatrae Sadia authorised engineer can assess the complete installation.

## 11.5 Exclusions

The following exclusions apply:

- ▶ Any third party repair or replacement costs, unless those costs have been agreed and authorised by Heatrae Sadia in writing prior to incurring those costs, will not be met.
- ▶ Heatrae Sadia accepts no liability for any third party damage, any indirect and consequential losses and any loss of earnings, loss of business, or losses in relation to stress and inconvenience, howsoever caused.

## 12. Decommissioning

### 12.1 Decommissioning procedure

- ▶ Isolate electrical supplies and make safe
- ▶ Isolate the water supply
- ▶ Drain the appliance
- ▶ Remove appliance
- ▶ Cap pipework

#### Environmental information

Products are manufactured from many recyclable materials. At the end of their useful life they should be disposed of at a Local Authority Recycling Centre in order to realise the full environmental benefits.

Insulation is by means of an approved CFC/HCFC free polyurethane foam with an ozone depletion factor of zero.

#### WEEE Declaration

Disposal of Waste Equipment by Users in Private Households in the European Union.



This symbol on the product indicates that this product must not be disposed of with your other household waste. Instead, it is your responsibility to dispose of your waste equipment by handing it over to a designated collection point for the recycling of waste electrical equipment. The separate collection and recycling of your waste equipment at the time of disposal will help to conserve natural resources and ensure that it is recycled in a manner that protects human health and the environment. For more information about where you can drop off your waste equipment for recycling, please contact your local city office, your household waste disposal service or the company where this product was purchased.



### 13. Spare parts

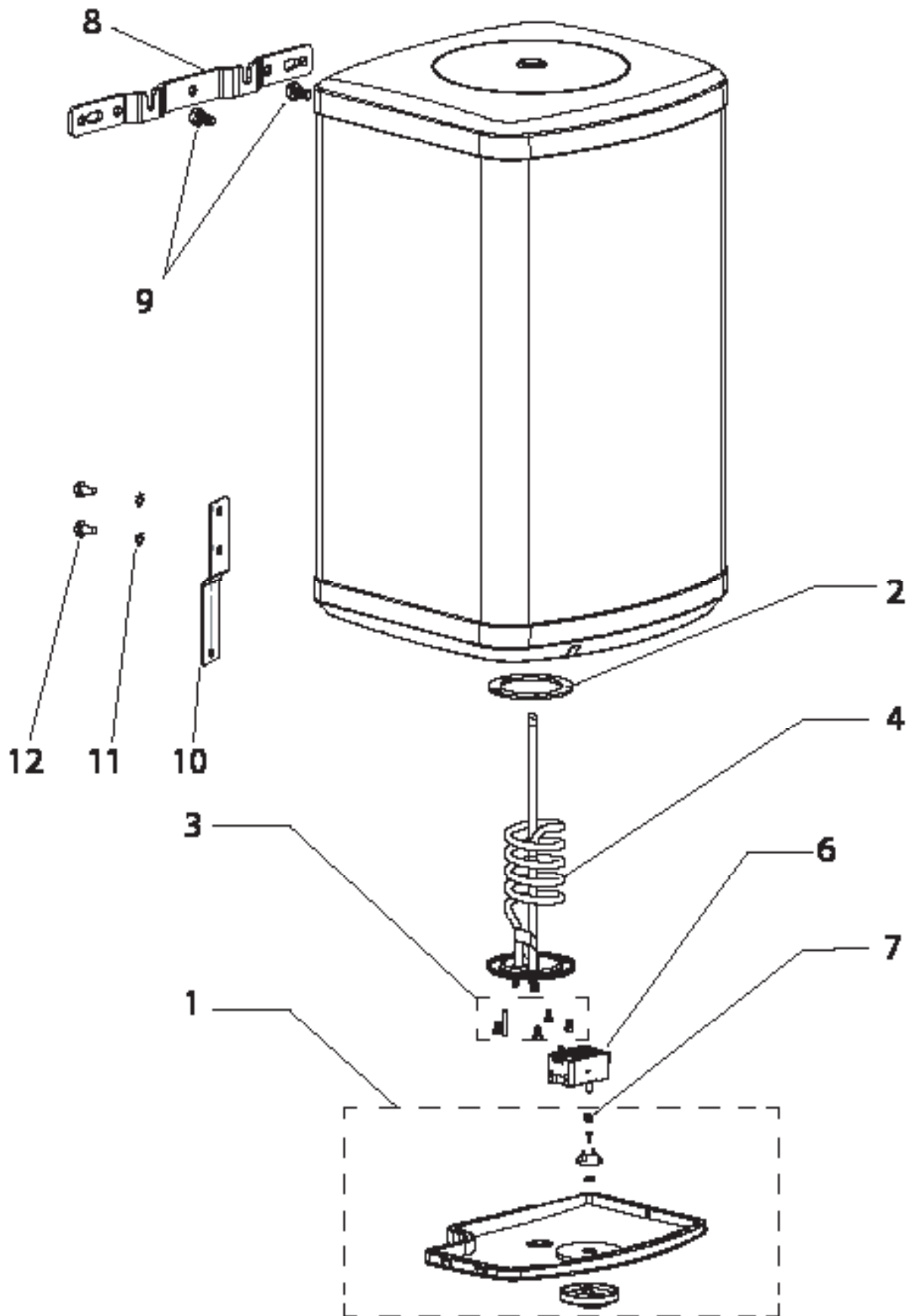

Figure 10: Spare parts

### 13.1 Spare parts list

Item	Description	Part Number
1	ELECTRICAL COVER WHITE SMALL + KNOB	7037703
2	IMMERSION HEATER GASKET	95611708
3	IMMERSION HEATER FIXINGS	7037707
4	IMMERSION HEATER ASSEMBLY - 3.0kW	7037711
5	INDICATOR LIGHT BBSC (not shown)	7037724
6	THERMOSTAT / THERMAL CUT OUT BBSC FOR KNOB CONTROL 30/50	7037726
7	THERMOSTAT / THERMAL CUT OUT ADAPTER	7037738
8	WALL BRACKET VERTICAL (NO BOLTS)	7037733
9	FIXING BRACKET BOLT KIT (Appliance SIDE ONLY)	7037737
10	BRACKET FIXING BOTTOM	7034212
11	M8 EXT TOOTH LOCK WASHER A2 SS	7034210
12	BOLT SECURITY TORX M8X16	7034211
13	COMPRESSION NUTS & OLIVES (NOT SHOWN)	95607253

Table 6: Spares table





# HEATRAESADIA

SMARTER | CLEANER | WARMER

## Electric Water Heating Co.

2 Horsecroft Place  
Pinnacles  
Harlow  
Essex CM19 5BT  
Tel: 0845 0553811  
E-Mail: sales@ewh.co.uk

## SPD

Special Product Division  
Units 9 & 10  
Hexagon Business Centre  
Springfield Road  
Hayes  
Middlesex UB4 0TY  
Tel: 020 8606 3567

## Parts Center

Tel: 0344 292 7057  
www.partscenter.co.uk

## Newey & Eyre

Unit 3-5 Wassage Way  
Hampton Lovett Ind. Estate  
Droitwich, Worcestershire  
WR9 0NX  
Tel: 01905 791500  
Fax: 01905 791501

## UK Spares Ltd

Unit 1155  
Aztec West  
Almondsbury  
Bristol BS32 4TF  
Tel: 01454 620500

Alternatively contact your  
local supplying merchant  
or wholesale branch or use  
our online stockist finder at  
www.interpartspares.co.uk

### SPECIFICATION ADVICE HOTLINE

t | 01603 420220 e | specifier@heatraesadia.com

### AFTER SALES SERVICE

t | 0344 871 1535 e | customer.support@heatraesadia.com

w | heatraesadia.com



### OUR NATIONWIDE NETWORK OF CUSTOMER SUPPORT ENGINEERS

Heatrae Sadia has its very own dedicated nationwide network of highly trained customer support engineers so you can have peace of mind that we're always here to help.

### PRODUCT RANGE

Full specification details on all our products are available to download from our website.

To support our corporate responsibility and sustainability charters and reduce our printed material we encourage you to download product brochures from our website.

In designing these files we have taken into account the need to access data on screen.

If you would like to receive a printed copy of our full product catalogue please call our literature hotline on 01603 420127.

Heatrae Sadia Heating may introduce modifications to their products from time to time. Consequently, the details given in this brochure are subject to alteration without notice.

Please follow us online:

