

## The solution The Drayton Condensate FreeFlo\*

Condensate FreeFlo has been developed by Drayton to solve the problem of frozen condensate pipes. Installed on an external wall where the condensate pipe exits a property, FreeFlo continually monitors the air temperature. When the outside temperature falls to 5°C it blows warm air down the pipe to ensure it remains free of ice in all weather down to -15°C. The airflow and temperature generated by FreeFlo automatically adapt to outside temperature fluctuations which maximises energy efficiency. FreeFlo is fully automatic with a weekly self test program and requires no intervention from householders.

### Benefits for householders

- Peace of mind - knowing the heating system will work all year round even in the coldest spells
- Fit and forget - once installed it operates and self tests automatically
- Safe and robust - no access to live parts and fully weatherproof
- Minimises energy consumption as it only heats to just above the minimum level to stop freezing - however cold it gets

### Features:

- Operates fully automatically - with weekly self test and auto restart after power loss
- Energy efficient - only operates when temperature falls below 5°C
- Quick and easy to install - on external wall with one power cable
- Automatically controls airflow rate and temperature - to ensure ice free pipes up to 3m at temperatures down to -15°C
- Continues to work during prolonged cold spells

### Benefits for installers

- Quick and easy to install and wire
- One visit required for a long term solution
- A neat and professional finish
- A cost effective solution



Drayton

Drayton

## Condensate FreeFlo™

The Drayton Condensate FreeFlo\* prevents ice build-up on external pipe runs from condensing gas and oil boilers. It monitors external air temperature and blows warm air down the condensate pipe when there is a risk of freezing.

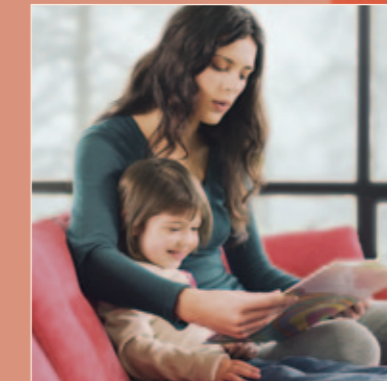

Available from:

**invenSYS**  
Controls

Sales: +44 (0) 845 130 5522 | Technical: +44 (0) 845 130 7722 | Fax: +44 (0) 845 130 0622 | Email: customer.care@invensys.com



Learn more about our full product range  
[www.draytoncontrols.co.uk](http://www.draytoncontrols.co.uk)



Our thoughts on the world of heating controls  
@DraytonHeating



Help and how to video guides  
[www.youtube.com/draytoncontrols](http://www.youtube.com/draytoncontrols)



D105-1

In accordance with our continuous improvement procedures, we reserve the right to change design features and specifications without prior notification. The Data contained in this document is for guidance only. Invensys Controls accepts no liability for any consequential losses, injury or damage resulting from the use of this document or the information contained within.

™ Condensate FreeFlo is a trademark of Invensys Controls UK Limited  
\* Patent Pending

HEATING



**invenSYS**  
Controls

\* Patent Pending

## Condensing boilers and UK winters

In the UK today condensing boilers account for 65% of all boilers installed. As the name suggests, condensing boilers produce condensate in the combustion process. This condensate has to be drained away from the boiler and in many cases this is achieved via an externally sited pipe.

The recent hard winters we have experienced, with cold spells that have lasted several days, have led to huge numbers of frozen and therefore blocked condensate pipes. This blockage causes the condensate to back up into the boiler. The consequences of this are...

**Research shows that at least 50% of all condensing boilers in the UK are installed with an external condensate run**

- Boiler stops working and the home is without heating and hot water at the coldest time of the year
- Water can seep out of the boiler into the home
- A service engineer typically needs to make 2 visits; firstly to remove the frozen pipe and then a return visit to refit the pipe after the cold snap is over



## Traditional Methods

There are a number of traditional methods that exist which are intended to prevent pipes freezing.

Solution	Issue
Place one pipe inside another to increase the insulation	This does not work at very low temperatures and for long periods - the pipes continue to freeze ❌
Add a condensate pump which removes the need for an external pipe run by pumping condensate into an internal drain	This can be a noisy and expensive solution which is also difficult to install ❌
Install a flush based solution where the water is stored and periodically flushed into the condensate pipe	This does not work at very low temperatures and for long periods - the pipes continue to freeze ❌
Fit a long flexible heater to the exterior of the pipe using cable ties and surround with insulation	An untidy and relatively expensive solution that can take over 2 hours to install ❌
Do nothing	The riskiest option as the boiler could stop working and the home will have no heating ❌

## How does Condensate FreeFlo work? ✓

- 1 Control unit:** Monitors air temperature and activates at temperatures of 5°C and below
- 2 Fan:** Blows air into the heater unit
- 3 Heater:** Energy efficient heater warms up air to prevent pipe freezing
- 4 Pipe:** Increasing levels of warm air travel through pipe as temperature drops to -15°C

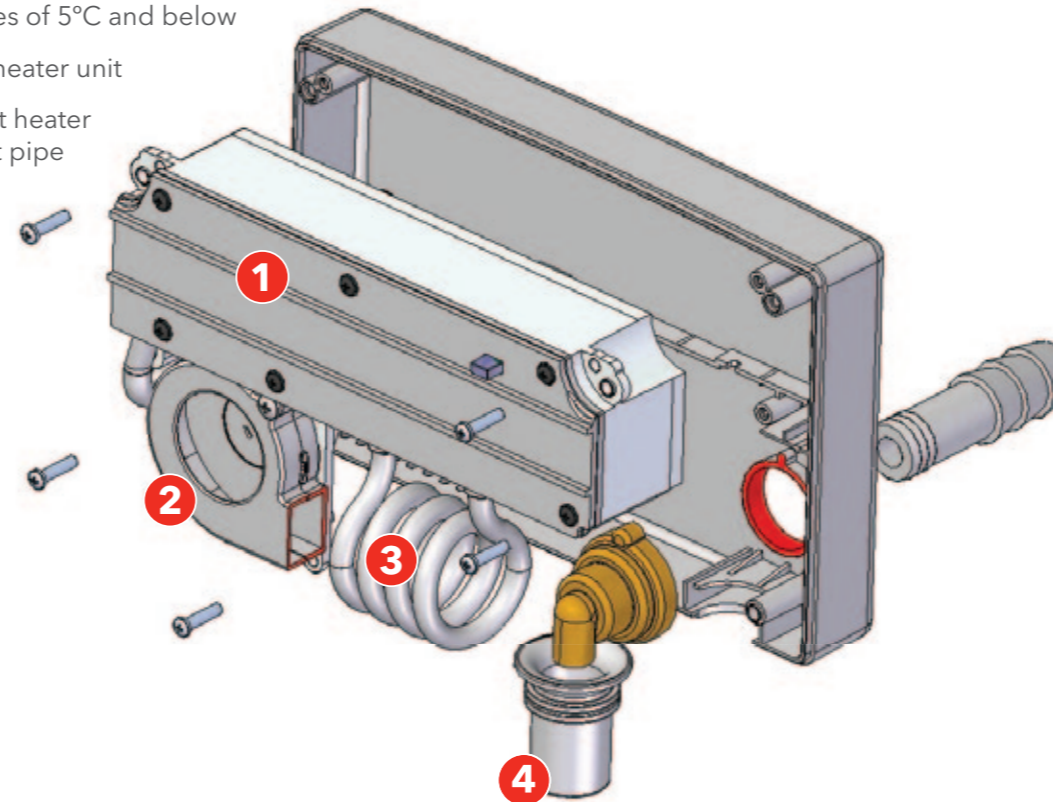

## Easy Installation

Follow these simple step-by-step instructions:

**Prepare:** A section of the existing pipe is removed and two screws are used to secure the rear housing to the wall

**Step 1 - Seal:** Seal the condensate pipe and ensure that the condensate flows through the device:

Insert the rubber hose **A** into the pipe adapter **B**  
Push both onto the condensate pipe

Place the outlet nozzle **C** in the slot on the rear housing below the pipe adapter

Join the outlet nozzle to the pipe leading to the drain

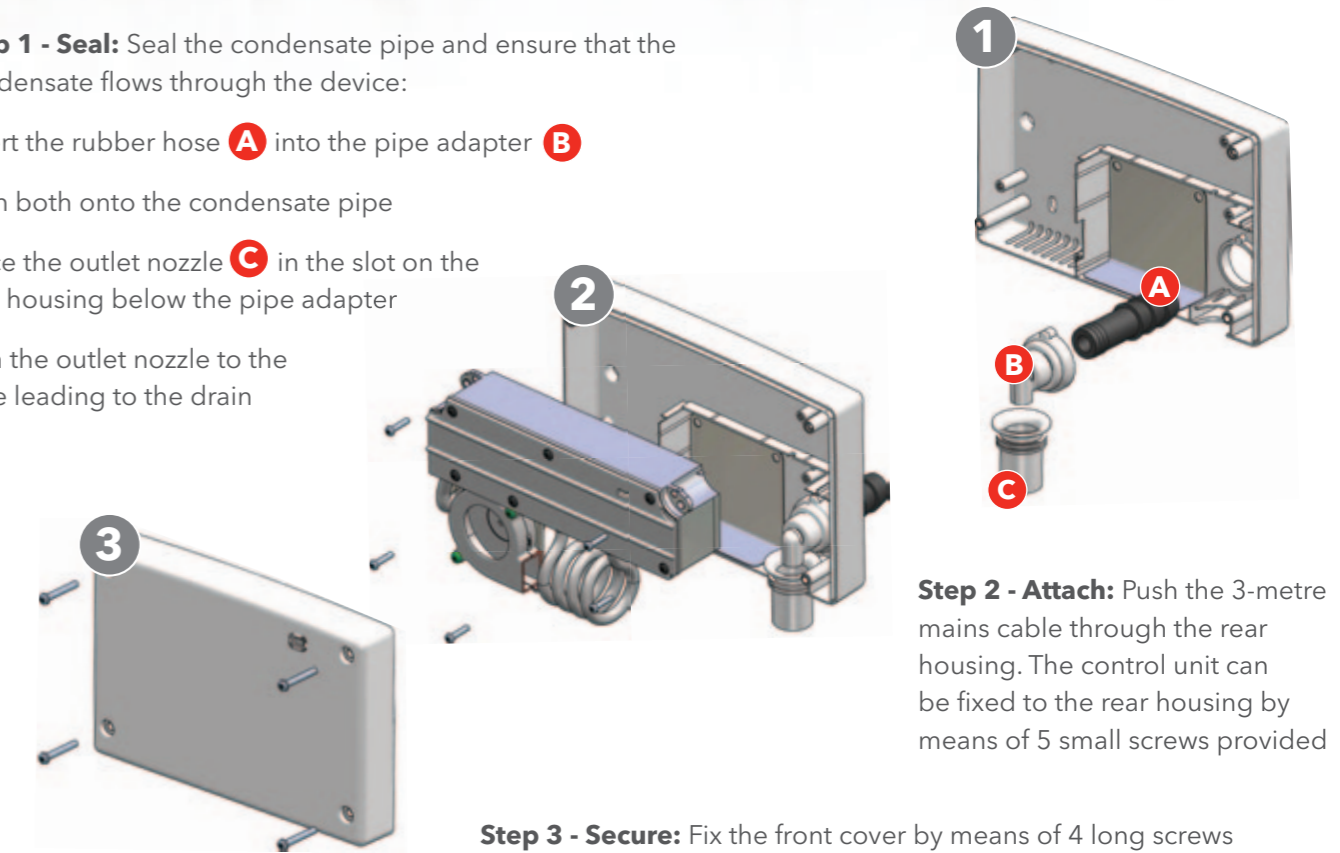

**Step 2 - Attach:** Push the 3-metre mains cable through the rear housing. The control unit can be fixed to the rear housing by means of 5 small screws provided

**Step 3 - Secure:** Fix the front cover by means of 4 long screws provided and insulate the condensate pipe with min 13mm lagging

**Final Step - Install:** Connect the mains cable to a convenient fused spur. When powered the unit will perform a short self test (3 seconds) and then the indicator light will be green